

TECHNICAL MANUAL

GENERAL SUPPORT AND DEPOT MAINTENANCE MANUAL

**SIGNAL
GENERATOR
AN/URM-149**

**HEADQUARTERS, DEPARTMENT OF THE ARMY
JUNE 1973**

The following are general safety precautions that are not related to any specific procedures and, therefore, do not appear elsewhere in this manual. These are recommended precautions that personnel must understand and apply during many phases of operation and maintenance.

WARNING

Operator and maintenance personnel should be familiar with the safety precautions before attempting work on this equipment. Failure to following requirements and observe safety precautions could result in injury or DEATH.

WARNING

DANGEROUS VOLTAGES EXIST IN THIS EQUIPMENT. Be careful when working on the klystron -650-volt reflector power supply circuit, or on the 115-volt/230-volt ac line connections.

WARNING

Be careful not to contact high-voltage connections or any power connections when using this equipment. Before working inside the equipment, discharge all high-voltage capacitors by short-circuiting them after the power has been turned off. Serious injury or DEATH may result from contact with these points.

WARNING

Performance of any field expedient repair creates a condition potentially dangerous to equipment and personnel. The equipment, so repaired, should be taken out of service as soon as possible for replacement of the defective parts.

TECHNICAL MANUAL }
 No. 11-6625-1633-45 }

HEADQUARTERS
 DEPARTMENT OF THE ARMY
 WASHINGTON, D.C., 29 June 1973

GENERAL SUPPORT AND DEPOT MAINTENANCE MANUAL

SIGNAL GENERATOR AN/URM-149

		Paragraph	Page
CHAPTER	1. GENERAL	1-1, 1-2	1-1
	2. FUNCTIONING OF EQUIPMENT	2-1 - 2-11	2-1
	3. GENERAL SUPPORT MAINTENANCE	3-1 - 3-16	3-1
CHAPTER	4. REPAIRS AND ADJUSTMENTS		
Section	I. Repairs	4-1 - 4-11	4-1
	II. Adjustment procedures	4-12 - 4-19	4-5
CHAPTER	5. DEPOT MAINTENANCE PROCEDURES		
Section	I. Depot maintenance	5-1, 5-2	5-1
	II. Depot overhaul standards.....	5-3 - 5-13	5-1
APPENDIX	REFERENCES.....	A-1
INDEX.....		Index-1

*This manual supersedes TM 11-6625-1633-45, 1 May 1968.

LIST OF ILLUSTRATIONS

<i>Number</i>	<i>Title</i>	<i>Page</i>
3-1	Signal Generator AN/URM-149, top view	3-2
3-2	Signal Generator AN/URM-149, bottom view	3-3
3-3	Signal Generator AN/URM-149, rf oscillator section removed, right side view.....	3-4
3-4	Signal Generator AN/URM-149, left side view.....	3-5
3-5	RF Oscillator Section, top view	3-6
3-6	RF Oscillator Section, right side view.....	3-7
3-7	RF Oscillator Section, left side view	3-7
3-8	Tracking Subassembly, bottom view.....	3-8
3-9	Terminal Board TB2-A1, parts location diagram	3-9
3-10	Terminal Board TB3-A2, parts location diagram	3-10
3-11	Terminal Board TB4-A3, parts location diagram	3-11
3-12	Chassis Terminal Boards, parts location diagram	3-12
3-13	Normal waveform diagram	3-16
3-14	Typical common emitter stage diagram	3-16
3-15	Transistor diode test connections	3-18
4-1	Tracking Potentiometers A4R20 and A4R23, mounting details	4-2
5-1	RF output frequency, test setup diagram.....	5-4
5-2	RF output power, test setup diagram.....	5-5
5-3	Internal modulation frequencies accuracy, test setup diagram	5-7
5-4	RF noise level measurement, test setup diagram	5-8
5-5	Tube socket voltage and resistance diagram	Fold-out
5-6	Resistor, inductor, and capacitor color code diagrams	Fold-out
5-7	Signal Generator AN/URM-149, block diagram.....	Fold-out
5-8 ①	Signal Generator AN/URM-149, schematic diagram (Part 1 of 2)	Fold-out
5-8 ②	Signal Generator AN/URM-149, schematic diagram (Part 2 of 2)	Fold-out

CHAPTER 1 GENERAL

1-1. Scope

a. This manual contains general support (gs) and depot maintenance instructions for Signal Generator AN/URM-149. It includes instructions appropriate to gs and depot maintenance for troubleshooting, testing, and repair of equipment. It also lists the test equipment required for gs and depot maintenance.

b. The complete technical manual for this equipment includes TM 11-6625-1633-12. The gs and depot maintenance parts list is contained in TM 11-6625-1633-45P.

c. The reporting of errors, omissions, and recommendations for improving this publication by the individual user is encouraged. Reports should be submitted

on DA Form 2028 (Recommended Changes to Publications) and forwarded direct to Commander, US Army Electronics Command, ATTN: AMSEL-MA-CR, Fort Monmouth, NJ 07703.

1-2. Maintenance Forms and Records

Maintenance forms and records which are to be used by maintenance personnel at all maintenance levels are listed in and prescribed by TM 38-750. For procedures, forms and records, and inspections required during administrative storage of this equipment, refer to TM 740-90-1.

CHAPTER 2

FUNCTIONING OF EQUIPMENT

2-1. Block Diagram Analysis

(fig. 5-7)

The AN/URM-149 is a signal source capable of producing unmodulated or frequency modulated (fm) signals in the 600 to 1,850 megahertz (MHz) range. The radio-frequency (rf) output can be modulated by an internal or externally generated sine wave to produce frequency modulation of the rf carrier at a controlled deviation range of 0 to 300 kilohertz (KHz). The rf output can also be pulse modulated by an externally produced pulse to produce step voltages. A continuous wave (cw) output is produced when no modulation is applied to the rf carrier.

a. Internal Modulator-Oscillator Circuit. The internal modulator-oscillator circuit is used for internal modulation of klystron oscillator A4V1. It is a sine wave source capable of producing five output frequencies: 1,000 hertz (Hz), 1,600 Hz, 20 KHz, 68 KHz, and 108 KHz. The circuit consists of five bridge-tee networks, oscillator V1, cathode follower V2, and amplifier V3. The sine wave output is applied through MODULATION selector switch S2 to amplifier A1V1 (*b* below). DEVIATION control resistor R35 determines the input level of the signal applied to A1V1.

b. Modulation Amplifier Circuit. The modulation amplifier circuit, consisting of amplifier A1V1 and cathode follower A1V2, receives modulating signals from the internal modulator-oscillator circuit (*a* above) or from EXT PULSE or EXT SINE input jacks J1 and J2, respectively. The amplified signal is applied directly from cathode follower A1V2 to the modulation tracking system in the klystron oscillator circuit where it is used to modulate klystron oscillator A4V1 by varying the reflector voltage. A portion of the output from cathode follower A1V2 is also applied through DEVIATION METER RANGE selector switch S3 to the deviation metering circuit (*c* below).

c. Deviation Metering Circuit. The deviation metering circuit amplifies and rectifies a portion of the output of cathode follower A1V2 (*b* above) for use in calibrat-

ing the amount of deviation from the rf center frequency. The proper meter multiplier is selected by DEVIATION METER RANGE selector switch S3. The output of amplifier A1V3 is applied through deviation meter adjustment resistor R1 to deviation meter M1.

d. Klystron Oscillator Circuit. The klystron oscillator circuit generates rf voltages within the range of 600 MHz to 1,850 MHz. The rf output is applied to RF OUTPUT jack J5 through contacts of coaxial relay K4.

e. Power Monitor Bridge Circuit. The power monitor bridge circuit is essentially used to measure the average power level of the klystron oscillator rf output. The oscillator output is applied to the circuit through contacts of probe switching relay K3.

f. Power Supplies.

(1) *Reflector and beam power supply.* The reflector power supply provides regulated -650 volts, direct-current (vdc) to the reflector of klystron oscillator A4V1. The beam power supply provides -325 vdc for the cathode of klystron oscillator A4V1.

(2) *Modulator and bridge power supply.* The modulator and bridge power supply consist of two regulated- power supplies operating from separate secondary windings of the same power transformer. One supply furnishes +250 vdc for the modulator and the other furnishes -108 vdc for the power monitor bridge.

(3) *Klystron filament power supply.* The klystron filament power supply is a transistorized, low ripple, regulated power supply that provides 6.3 vdc for the klystron filament.

2-2. Analysis of Internal Modulator-Oscillator Circuit

(fig. 5-8 ①)

a. The frequency of oscillation of the internal modulator-oscillator circuit is controlled by the bridge-tee

network selected by INTERNAL MODULATION FREQUENCY selector switch S1. The input to the grid of resistance-capacitance pentode oscillator V1 is determined by the negative (degenerative) feedback loop consisting of capacitor C25, resistor R27, and one of the bridge-tee networks. Since the selected bridge - network offers minimum impedance at its tuned frequency, the negative feedback to the grid of oscillator V1 is minimum at the tuned frequency.

b. Automatic amplitude control is maintained by positive (regenerative) feedback. This is developed through capacitor C23 and the amplitude control network consisting of resistors R14 and R15, capacitor C22, and the voltage divider network comprised on IKC potentiometer R16 resistor R17, and 1.6KC, 20KC, 68KC, and 108KC potentiometers R18 through R21, respectively. Potentiometers R16 and R18 through R21 are used as adjustments to set the amplitude of the oscillations at the selected frequency. Automatic voltage control for the cathode of oscillator V1 is obtained by constant temperature thermistor RT1, connected at the junction of 1 KC potentiometer R16 and resistor R17. Diodes CR28 and CR29, together with capacitor C51, maintain a constant voltage through the filament (pins 3 and 7) of temperature controlled thermistor RT1. When a change occurs in the output signal amplitude, the resulting current change varies the resistance of thermistor RT1. This, in turn, varies the cathode resistance of oscillator V1 to maintain a constant output voltage.

c. The output signal from oscillator V1 is connected through resistor R23 to the grid of cathode follower V2, which acts as an isolator between the oscillator and modulation amplifier V3. Modulation amplifier V3 provides a constant current source for the cathode follower. The output of cathode follower V2 is fed back through capacitor C23 and INTERNAL MODULATION FREQUENCY selector switch S1C for automatic amplitude control. In addition, the output of cathode follower V2 is applied through capacitor C28, resistor R28, and coupling capacitor C27 to MODULATION selector switch S2B.

NOTE

Plate voltage is only supplied to the internal modulator-oscillator circuit when MODULATION selector switch S2 is in the INT SINE position.

2-3. Analysis of Modulation Amplifier Circuit
(fig. 5-8 ①)

a. The output signal from the internal modulator-oscillator circuit (para 2-2) or from an external sine wave or pulse source is applied through MODULATION selector switch S2 and DEVIATION adjustment potentiometer R35 to the grid of modulation amplifier A1V1. DEVIATION adjustment potentiometer R35 controls the input signal amplitude that is applied to amplifier A1V1. Trimming capacitor C29 controls the network (capacitor C29 and resistor R32) response to an external sine wave modulating signal.

b. The output of modulation amplifier A1V1 is applied through resistor A1R9 to the grid of cathode follower A1V2. Cathode follower A1V2 acts as an isolation stage between modulation amplifier A1V1, the reflector of klystron oscillator A4V1, and the deviation metering circuit. A portion of the A1V2 output is fed back to the grid of A1V1. Negative feedback is used to stabilize the gain and reduce distortion introduced by modulation amplifier A1V1.

2-4. Analysis of Deviation Metering Circuit
(fig. 5-8 ①)

a. When MODULATION selector switch S2 is in the INT SINE, EXT SINE, or EXT PULSE position, a portion of the modulated signal is applied to the deviation metering circuit for measurement. The deviation metering circuit consists of amplifier A1V3, two bridge circuits, and deviation meter M1.

b. Operation of the deviation meter, for each pertinent position of MODULATION selector switch S2, is described below:

(1) *EXT PULSE position.* The external pulse input is applied through switch S2C and METER PULSE SENS potentiometer A1R2 to the full-wave bridge rectifier, consisting of diodes A1CR1 through A1CR4. The rectified voltage is applied through out of three range resistors: A1R20, A1R21, or A1R22 (selected by the position of DEVIATION METER RANGE selector switch S3) to deviation meter M1. Deviation meter M1, in series with the calibrating resistors and in parallel with the bridge, indicates a signal level proportional to the kilohertz deviation produced by the modulating pulse.

(2) *INT or EXT SINE position.* The internal or external sine wave signal is applied through one of three frequency range resistors (A1R17, A1R18, or A1R19)

selected by the DEVIATION METER RANGE selector switch and applied to the grid of amplifier A1V3. The output of amplifier A1V3 is applied through coupling capacitor A1C1 to the full-wave rectifier bridge, consisting of diodes A1CR5 through A1CR8. The rectified output, in parallel with deviation meter adjustment potentiometer AIR1, is applied across deviation meter M1. Deviation meter M1 indicates a signal level proportional to the sine wave modulation signal amplitude and, therefore, proportional to the kilohertz deviation ((1) above) .

2-5. Analysis of Klystron Oscillator Circuit (fig. 5-8 ②)

a. The klystron oscillator circuit consists of a klystron oscillator, a cavity assembly, and a mechanical tracking system. The operating range of the klystron oscillator is from 600 MHz to 1,850 MHz.

b. The operation of the klystron oscillator is controlled by the position of MODULATION selector switch S2. With MODULATION selector switch S2 in the OFF position, klystron oscillator A4V1 is cut off and the power monitor bridge circuit may be balanced using ZERO SET potentiometers R51 and R52.

c. When MODULATION selector switch S2 is in the CW position, the klystron tube operates as a velocity modulated oscillator. The external cavity, in the form of a coaxial transmission line, consists of two concentric cylinders. The klystron tube is inserted at one end of this line so that the outer cylinder makes contact with the first interaction grid (the one closer to the cathode), and the inner cylinder makes contact with the second interaction grid. At the other end of the line, the circuit is completed by a movable shorting plunger. The position of the plunger determines the resonant frequency of the cavity. Four tubes, protecting from the sides of the cavity, permit the coupling of rf energy to the output attenuator and the power monitor bridge.

d. The cathode of klystron tube A4V1 is fixed at -325 volts by the beam power supply, while the reflector voltage of the tube is varied with the position of klystron tracking potentiometer A4R20. The maximum negative reflector voltage is limited by the reflector power supply voltage (-650 volts) and the setting of 1850 MC potentiometer A4R19; the minimum reflector voltage is determined by the setting of 600 MC potentiometer A4R3. In

order to maintain the required phase between the oscillations, as the frequency is changed by varying the position of the shorting plunger, klystron tracking potentiometer A4R20 is mechanically gauged to the movements of the shorting plunger.

e. When MODULATION selector switch S2 is in the INT SINE position, the modulation signal from cathode follower A1V2 is applied to the reflector of the klystron. The reflector voltage is thereby sinusoidally varied to produce a frequency modulated output. The frequency of the modulating signal is selected by the position of INTERNAL MODULATION FREQUENCY selector switch S1. The available frequencies are 1,000 Hz, 1,600 Hz, 20 KHz, 68 KHz, and 108 KHz.

f. In the EXT SINE position of MODULATION selector switch S2, and with an external sine wave modulating signal applied, the operation of the klystron is identical as in the INT SINE position of the MODULATION selector switch (*e* above). The external modulating signal frequency can vary over the range of 250 Hz to 108 KHz.

g. In the EXT PULSE position, the operation is similar to the INT SINE position (*e* above) except that with an external pulse applied, the klystron will produce an fm signal instantaneously varied at the same repetition rate as the modulating pulse. In between pulses, the carrier center frequency is obtained as an output. When the pulse is present, the output frequency is shifted above or below the center frequency by an amount proportional to the amplitude of the pulse. The modulation pulse repetition frequency (prf) can be approximately 300 to 380,000 pulses per second (pps) .

h. The function of two of the four tubes projecting from the cavity (*c* above) is to couple the rf signal by means of attenuator probes to RF OUTPUT jack J5.. The attenuators consist of circular waveguides operated below cutoff. Electromagnetic energy injected into the waveguides is attenuated exponentially with the distance from the cavity. The rf power is coupled out by two variable-position probes within the waveguide tubes. Probe Z1 is used for frequencies below 825 MHz and probe Z2 for frequencies above 825 MHz. Coaxial relay K4 functions as an rf switch. It connects the proper attenuator probe to the RF OUTPUT jack as a function of the center frequency selector handwheel position.

i. For this mode of transmission, the rate of attenuation in the attenuator tube is constant. This mode of transmission is known as the TM₀₁ mode. The position of the probe assembly, controlled by the ATTENUATOR control knob through a gear train, determines the output power from the rf oscillator. The output is indicated from -7 decibel meter (dbm) to -127 dbm below 1 millivolt into 50 ohms on the MICROVOLTS/ - DBM dial scale. The output power can be read directly from the scale within the tolerance limits of the signal generator only if the POWER SET control knob is adjusted for a POWER SET indication on power set-zero set meter M2.

2-6. Analysis of Power Monitor Bridge Circuit (fig. 5-8 ②)

a. The power monitor bridge circuit consists of an audio oscillator, an output voltage monitor, and a transformer-coupled self-balancing bridge. The active elements in the self-balancing bridge are thermistors RT2 and RT3 that are located in the other two tubes projecting from the klystron cavity (para 2-5c).

b. The audio oscillator is composed of transistors Q5 and Q6 and associated components. The transistors are coupled together through a series resonant circuit, comprised of capacitor C50 and coil L3, that determines the frequency of the oscillator.

c. The output voltage monitor consists of fullwave rectifier CR24 through CR27 and power set-zero set meter M2. METER SENSITIVITY potentiometer R67 controls the meter sensitivity. Resistors R64 and R66 determine the null point of the meter when no audio voltage is present.

d. The self-balancing bridge network consists of the center-tapped secondary winding of coupling transformer T4, resistor R49, capacitor C46, and thermistor RT2 or RT3 (which is used to cover the low and high frequency ranges, respectively). The dc current flowing through the selected thermistor is controlled by ZERO SET potentiometers R51 and R52. Power monitoring in the AN/URM-149 is achieved as follows:

(1) The power monitor bridge measures power by the use of variable resistance thermistors in the self-balancing bridge circuit. The thermistor resistance varies inversely with temperature. Changes of thermistor resistance can be caused by three variables: environmental

temperature, audio oscillator output, and the magnitude of rf power coupled to the thermistor.

(2) The thermistor is dc biased, at room temperature, to a resistance of approximately 130 ohms. This causes an initial unbalance in the self-balancing bridge and an audio output appears between pins 5 and 6 of transformer T4, and ground. This voltage is amplified by transistors Q5 and Q6 and coupled back through transformer T4 to the thermistor, and thereby balances the bridge.

(3) METER SENSITIVITY potentiometer R67 is factory adjusted so that power set-zero set meter M2 indicates zero with 1 milliwatt ((mw)) of audio power and zero rf power across the thermistor. When MODULATION selector switch S2 is rotated from OFF to CW, rf power is substituted for audio power in the thermistor. This substitution is caused by the self-balancing feature of the bridge. Meter M2 now reads up scale. When the POWER SET control knob is adjusted, the rf power absorbed by the thermistor is changed. The POWER SET control knob is adjusted until power set-zero set meter M2 indicates POWER SET. This indication corresponds to a dissipation of 0.3 mw of rf power and 0.7 mw of audio power in the thermistor. The POWER SET control knob is mechanically gauged to a hair line indicator which sets the reference for the ATTENUATOR control knob.

2-7. Analysis of Reflector Power Supply (fig. 5-8 ①)

The reflector power supply is a regulated power supply that furnishes the reflector voltage for the klystron. *It is referenced to the beam power supply in order to maintain the reflector negative with respect to the cathode (para 2-8).* Fullwave bridge rectifier diodes CR6 through CR9 provide a full-wave rectified output to a pi type filter, consisting of capacitors C35, C36, and choke L1B. The output of the filter is applied to series regulator tube A3V5. Dual triode A3V6 functions both as a control tube and an amplifier whose input is determined by voltage regulator tubes A3V7, A3V8, resistor A3R4, REFL-650 potentiometer A3R8, and resistors A3R9 and A3R19. The circuit functions as follows:

a. The alternating-current (ac) voltage from the secondary winding of transformer T2 is rectified by full-wave bridge rectifier diodes CR6 through CR9. The rectified voltage is filtered by a pi filter consisting of

capacitor C35, choke L1B, and capacitor C36.. The resulting dc voltage appears at the plate of series regulator tube A3V5. The grid of regulator tube A3V5 is connected to the plate (pin 1) of voltage control tube A3V6. The two triode sections of voltage control tube A3V6 are connected in cascade and operate as a two-stage dc amplifier. The cathodes (pins 3 and 8) of control tube A3V6 are tied to the cathodes of voltage reference tubes A3V7 and A3V8 respectively. The grid (pin 7) of control tube A3V6 is connected to the wiper arm of REFL-650 potentiometer A3R8. Since the cathodes of control tube A3V6 are maintained at a fixed voltage by reference tubes A3V7 and A3V8, voltage variations in the power supply output will appear at pin 7 of A3V6. These changes are amplified by A3V6 and are applied to the grid of regulator tube A3V5. The voltage drop across regulator tube A3V5 changes and restores the power supply to the preset voltage.

b. The circuit also provides -650 volts at the negative terminal of supply resistor A3R4. This voltage is applied through pin C of jack A3J2 and pin A of jack A4J3 to the reflector tracking circuit. Resistor A3R4 is in series with REFL -650 potentiometer A3R8 and resistor A3R9, which is referenced to the -325-volt beam power supply at the junction of GRID BIAS potentiometer A3R11 and capacitor A3C1. In parallel with these resistors is a bleeder network formed by series resistors A3R5 and A3R6. When MODULATION selector switch S2 is in the OFF position, the voltage at the junction of resistors A3R5 and A3R6 is connected through pin B of jack A3J2 and the switch to the grid of the klystron. This voltage is approximately 20 volts more negative than the beam voltage, and therefore cuts off the klystron.

2-8. Analysis of Beam Power Supply

(fig. 5-8 ①)

a. The beam power supply is a regulated power supply that furnishes the klystron beam voltage. Except when MODULATION selector switch S2 (fig. 2-7) is at OFF, the klystron bias is tapped from the beam power supply and maintains the grid positive with respect to the cathode. This permits the klystron to oscillate. The power supply uses a full-wave bridge diode rectifier comprised of diodes CR1 through CR4 connected to a ripple filter through 60-second delay relay K1. Power pentode A3V1 is used as a series regulator tube. Dual triode A3V2 functions as a control tube, and regulator tubes A3V3 and A3V4 act as voltage reference tubes.

The operation of power supply is similar to the reflector power supply (para 2-7) except that time delay relay K1 allows the klystron a 60-second warmup period before operation of power relay K2 energizes the beam power supply. KLYSTRON indicator lamp DS2 lights (yellow) when the -325-volt beam power supply is operating.

2-9. Analysis of Modulator and Bridge Power Supply

(fig. 5-8 ②)

a. The modulator power supply furnishes regulated dc plate voltage to all tubes in the modulator-oscillator, the modulation amplifier, and the deviation meter circuit. The output of full-wave bridge rectifier diodes CR16 through CR19 is filtered by capacitors C42 and C43, and choke 12 and is applied to series regulator tube V4 (of which only one section is used). Dual triode amplifier A2V2 functions as a control amplifier and operates from the reference voltages furnished by voltage regulator tubes A2V3 and A2V4. The operation of the modulator power supply is essentially the same as the operation of the reflector power supply (para 2-7). Resistors A2R7, A2R9, and 250V voltage adjust potentiometer-A2R8 comprise a bleeder circuit across the output.

b. The function of the bridge power supply is to furnish a constant negative 108-volt potential to energize the power monitor bridge circuit (para 2-8). Full-wave bridge rectifier diodes CR20 through CR23, provide a full-wave rectified output to pentode series regulator tube V5. Capacitor C44 acts as a filter. Dual triode amplifier A2V1 functions as a control amplifier and operates from the reference voltage furnished by voltage regulator tube A2V5. The operational difference between the modulator and bridge power supply is as follows: The bridge power supply reference voltage for amplifier tube A2V1 is obtained by the voltage divider network consisting of regulator tube A2V5 and resistor A2R12. The voltage divider is connected between the +250 volt regulated modulator power supply and the -108 volt bridge power supply output voltage. The grid of amplifier tube A2V1 is connected to the junction of regulator tube A2V5 and resistor A2R12. The grid voltage is therefore the difference between the constant voltage potential across regulator tube A2V5 and the 108-volt output of the bridge power supply. Any voltage change in the bridge power supply output causes amplifier A2V1 to apply a control signal to series regulator tube V5 to prevent the output voltage from changing.

2-10. Analysis of Klystron Filament Power Supply

(fig. 5-8 ①)

a. The klystron filament power supply consists of full-wave bridge rectifier diodes CR10 through CR13, pi filter capacitors C40 and C41, and resistor R42, series regulator transistors Q1 and Q2, and high gain differential amplifier transistors Q3 and Q4. Oven HR2 assures operation within the specified temperature range. Components within oven HR2 are shown within the dotted lines.

b. The ac output voltage from the secondary winding of transformer T2 is rectified by the full-wave bridge rectifier consisting of diodes CR10 through CR13. The output of the rectifier is filtered by a pi filter consisting of capacitor C40, resistor R42, and capacitor C41, and appears at the collectors of series regulator transistors Q1 and Q2. Differential amplifiers Q3 and Q4 provide feedback (derived from KLY FIL potentiometer R70) for transistors Q1 and Q2. The reference voltage for the differential amplifiers is set by Zener diode CR14. Zener diode CR15 provides a constant reference voltage for the base of transistor Q2 and the collector of transistor Q4.

2-11. Analysis of Power Distribution

(fig. 5-8)

a. Signal Generator AN/URM-149 can be operated from either a 115 or a 230 vac., 60 Hz, single phase power source. POWER OFF toggle switch S8 controls the application of input power and switch S9 (located on the back panel) selects operation from either 115 volt or 230 volt power lines. POWER indicator lamp DS1 lights (red) whenever power is applied to the unit.

b. Primary power is applied to the signal generator through 3 AMPS fuses F1 and F2 and is filtered by rfi filters FL1 and FL2. POWER OFF toggle switch S8 is coupled to the split primary windings of transformers T1,, T2,, and T3.. The primaries of transformers T1, T2, and T3 can be in series or in parallel, depending upon the position of switch S9 (a above).

c. With switch S9 in the 115V position, the primaries of each transformer are connected in parallel; with switch S9 in the 230V position, the primaries of transformers T1, T2, and T3 are in series. Blower motor B1 is a whisper fan that provides cooling for the unit.

CHAPTER 3

GENERAL SUPPORT MAINTENANCE

3-1. General Maintenance Instructions

a. The maintenance procedures performed at the general support category of maintenance are actions which have been designed to anticipate potential problem areas for the purpose of correcting a possible trouble before it results in equipment outage. The action to be taken consists mainly of the following:

(1) Visual inspection of the equipment for the purpose of determining general condition, unusual noise, and observing meter indications. Generally, the equipment will remain operational when these inspections are made.

(2) Repair or replacement of parts that have a definite life expectancy.

b. The general support maintenance procedures are not complete in themselves but supplement the procedures performed at the organizational category and include any additional techniques required to perform maintenance on the AN/URM-149.

3-2. Tools, Materials, and Test Equipment Required

- a.* Multimeter TS-352B/U.
- b.* Differential Voltmeter ME-202.
- c.* Oscilloscope AN/USM-140.
- d.* Wattmeter AN/UPM-98.
- e.* Frequency Meter TS-186/UP.
- f.* Modulation Meter ME-57/U.
- g.* Electronic Voltmeter AN/URM-145.
- h.* Electronic Equipment Tool Kit TK-100/G.

3-3. Troubleshooting Techniques

To be effective, troubleshooting must be systematic; it will be necessary to perform a sequence of operational

checks, observations, and measurements before the cause of a trouble is revealed.

a. The first step in servicing a defective equipment is to sectionalize the fault. Sectionalization means tracing the fault to the major equipment component. The second step is to localize the fault. Localization means tracing the fault to the defective stage. The third step, isolation, means tracing the fault to the defective component part. Some faults, such as burned out resistors, can often be isolated by sight, smell, or hearing. The majority of faults, however, must be isolated by checking voltages, resistances, and signal levels.

b. Whenever an equipment trouble occurs, make a visual inspection of all equipment controls, and cable connections before performing any detailed troubleshooting procedures. When the trouble has been isolated to a particular functional group, isolate the trouble to the defective assembly or unit.

c. In performing the localization and isolation procedures outlined in *a* and *b* above, one or more of the techniques specified below may be applied.

CAUTION

Before connecting the signal generator to the ac power input source, check the position of switch S9. Operation of the signal generator from a 230 vac power source with switch S9 in the 115V position may cause serious damage to the equipment.

(1) *Voltage measurements.* Portions of the equipment are transistorized. When measuring voltages, use tape or sleeving (spaghetti) to insulate the entire test prod, except for the extreme tip. A momentary short can damage a transistor. Use the same or equivalent electronic multimeter specified on the voltage and resistance diagrams.

(2) *Resistance measurements.* Make resistance measurements only as directed on voltage and resistance diagrams or charts. For transistorized circuits, use only the ohmmeter ranges specified; otherwise, indications obtained will be inaccurate.

CAUTION

Before using any ohmmeter to test transistors or transistor circuits, check the open-circuit voltage across the ohmmeter test leads. Do not use the ohmmeter if the open circuit voltage exceeds 1.5 volts.

Also, since the RX1 range normally connects the ohmmeter internal battery directly across the test leads, the comparatively high current (50 milliamperes (ma) or more) damage the transistor under test. As a general rule, the RX1 range of any

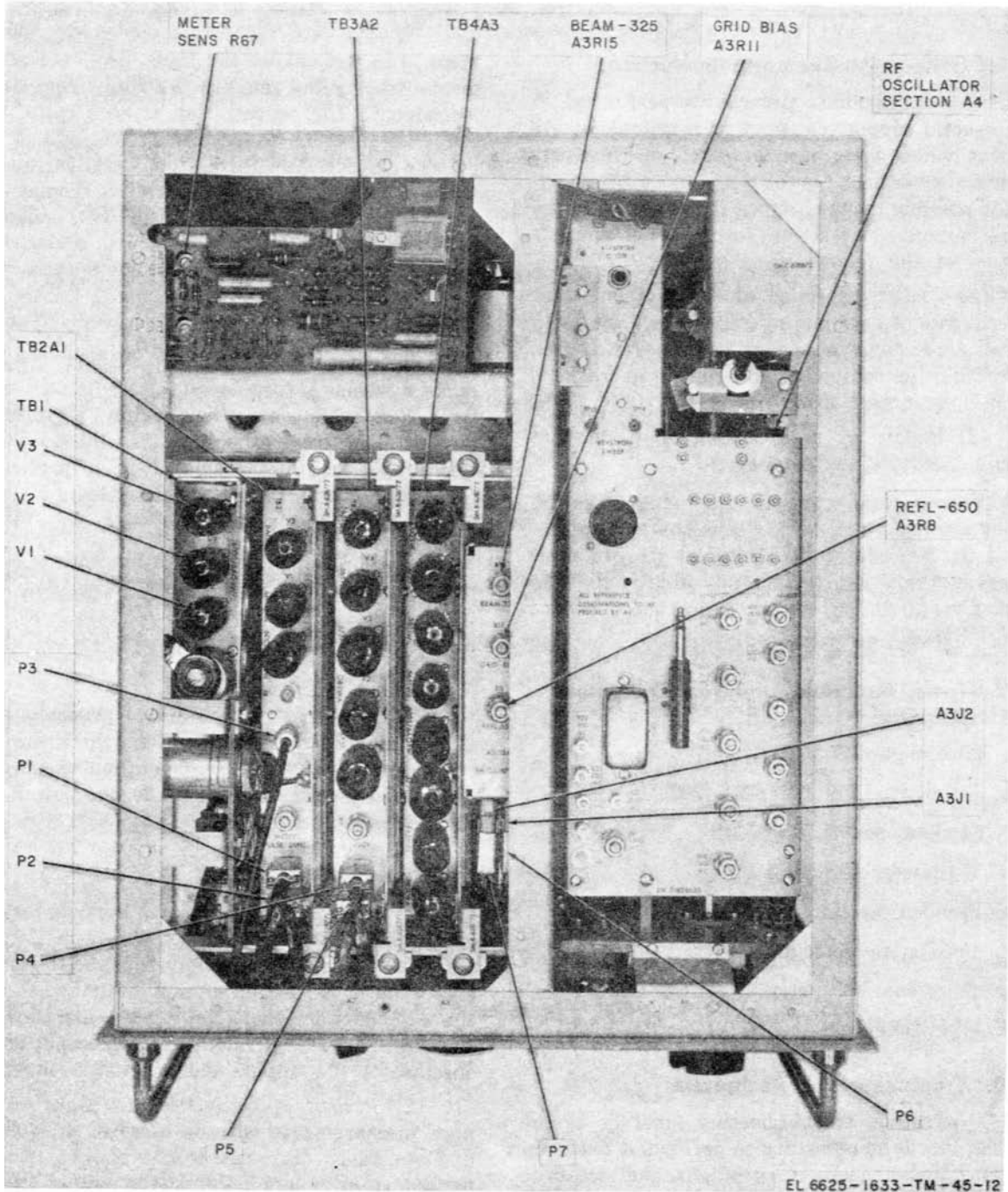

Figure 3-1. Signal Generator AN/URM-149, top view.

ohmmeter should not be used when testing low-powered transistors.

(3) *Test points.* The rf head of the signal generator is equipped with test jacks to facilitate connection of test equipment. The test points should be used whenever

possible to avoid needless disassembly of the unit. The test points are shown on the parts location diagrams (fig. 3-1 through 3-12) and on the main schematic diagram (fig. 5-8).

(4) *Wave shape.* Compare the wave shape obtained

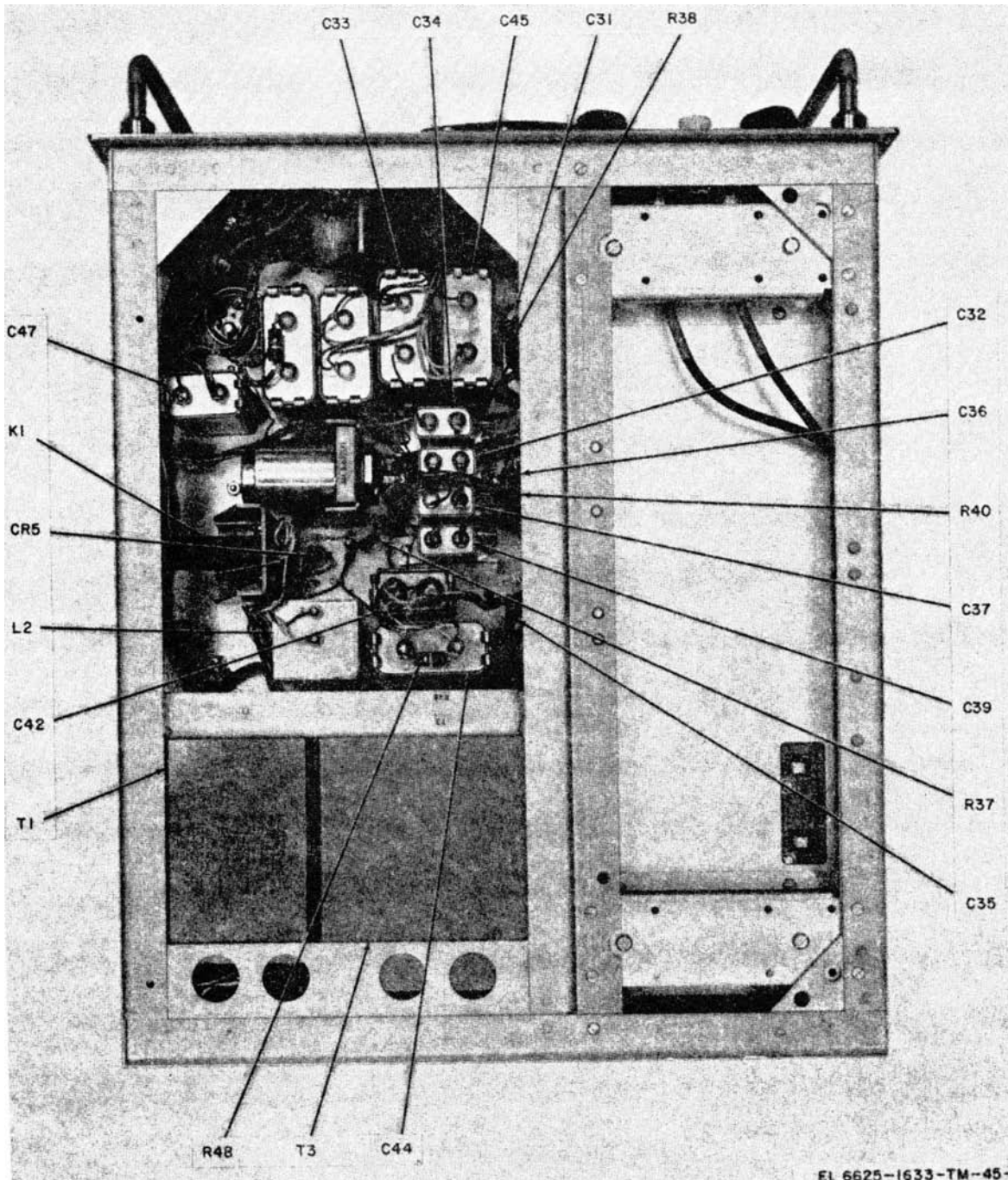

Figure 3-2. Signal Generator AN/URM-149, bottom view.

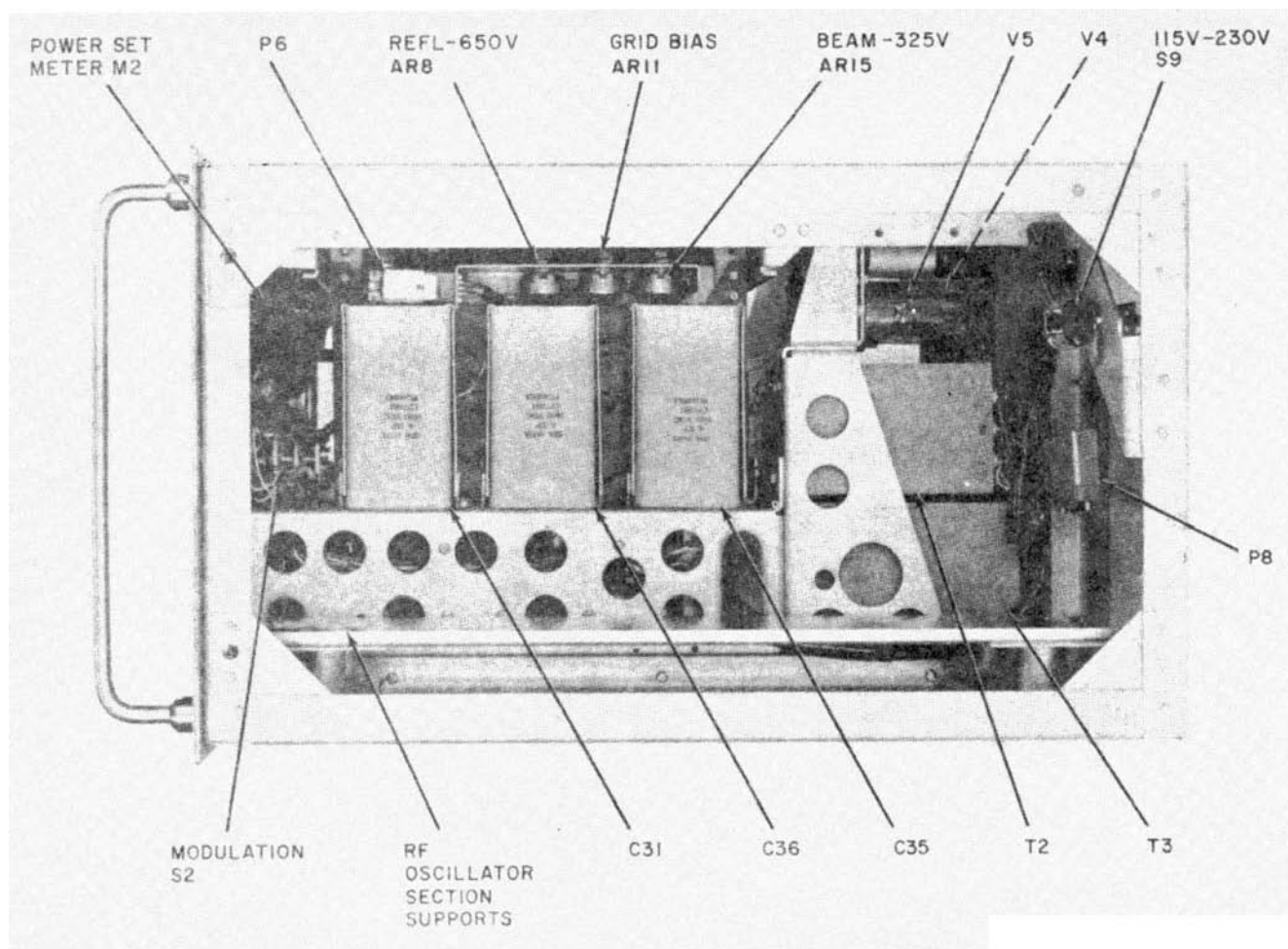

Figure 3-3. Signal Generator AN/URM-149, rf oscillator section removed, right side view.

at the specified test point and under the conditions specified in paragraph 3-7.

(5) *Intermittent troubles.* In all tests, the possibility of intermittent troubles should not be overlooked. If present, this type of trouble often may be made to appear by tapping or jarring the equipment. Make a visual inspection of all wiring and connections to the unit. Test the wiring for loose connections by moving wires and components with an insulated tool.

3-4. Checking Filament and Plate Voltage Circuits for Shorts

a. When any of the following conditions exist, check for short circuits and eliminate the troubles before applying power to the equipment.

(1) When maintenance checks and services indicate that the POWER indicator lamp will not light nor any of the tube filaments are energized when power is applied to the unit.

(2) When maintenance checks and services indicate that no output is obtained under any condition.

(3) When fuses repeatedly blow.

b. The conditions for testing are as follows:

(1) Remove the signal generator from its case by releasing the two cam locks at the rear of the carrying case and the two screws on either side and sliding the chassis out of the carrying case by pulling on the panel-mounted handles.

(2) Remove all tubes and indicator lamps.

CAUTION

Do not rock or rotate a tube when removing it from a socket; pull it straight out with a tube puller.

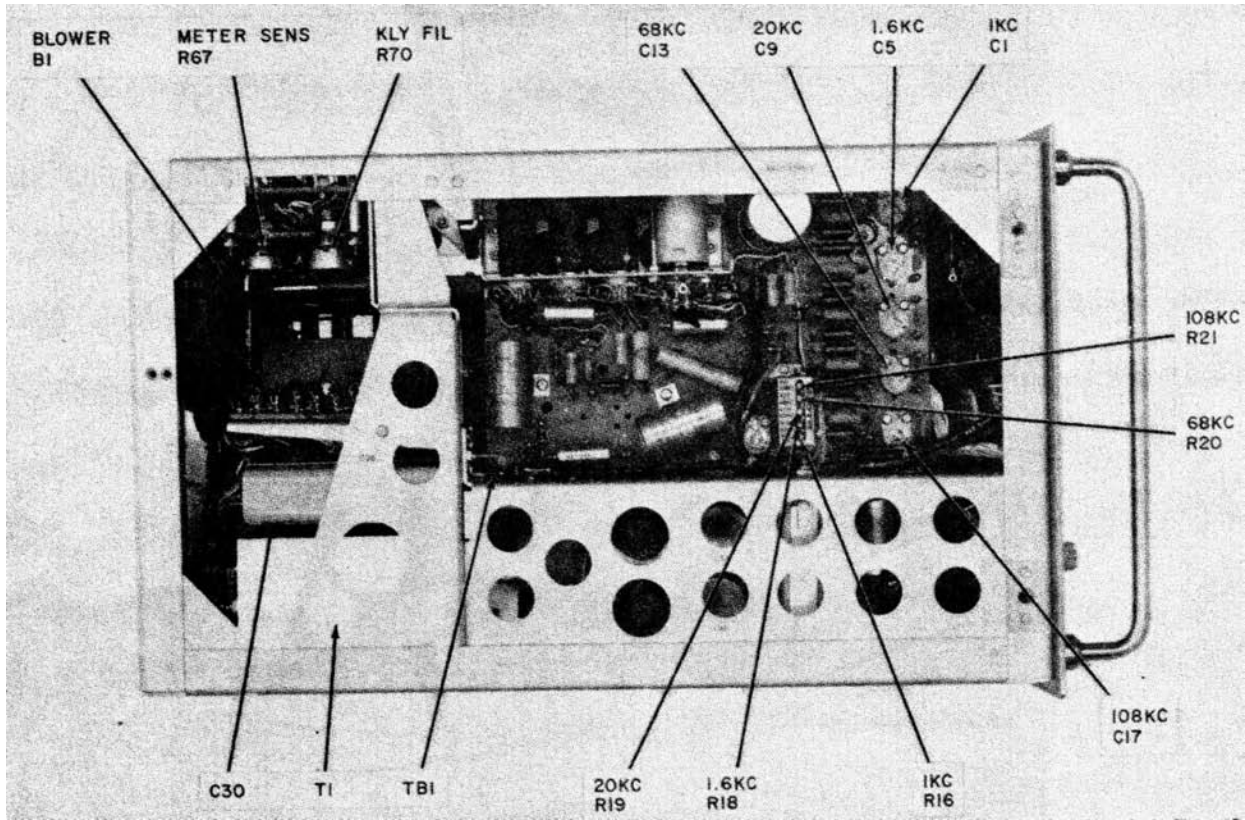

Figure 3-4. Signal Generator AN/URM-149, left view.

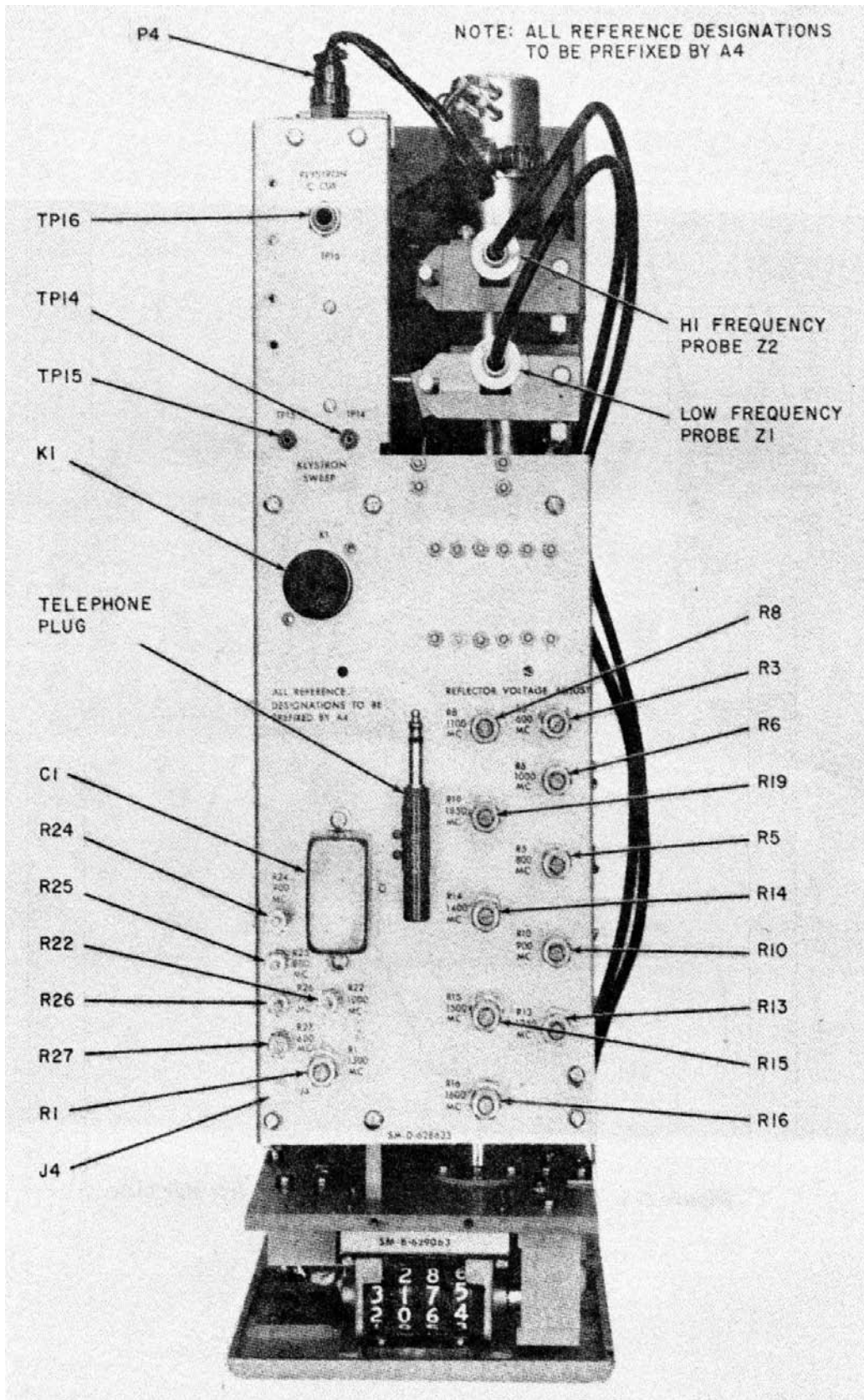

Figure 3-5. RF Oscillator Section, top view.

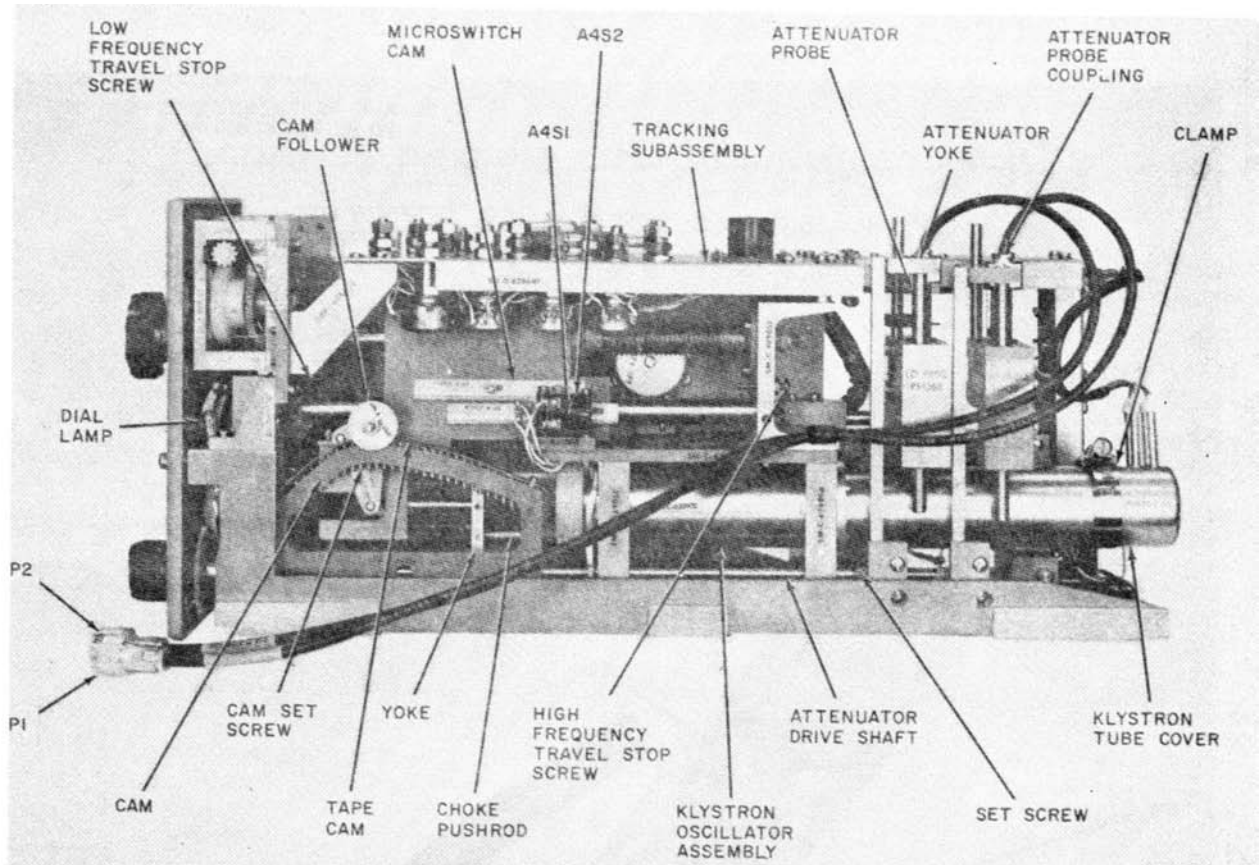

Figure 3-6. RF Oscillator Section, right side view.

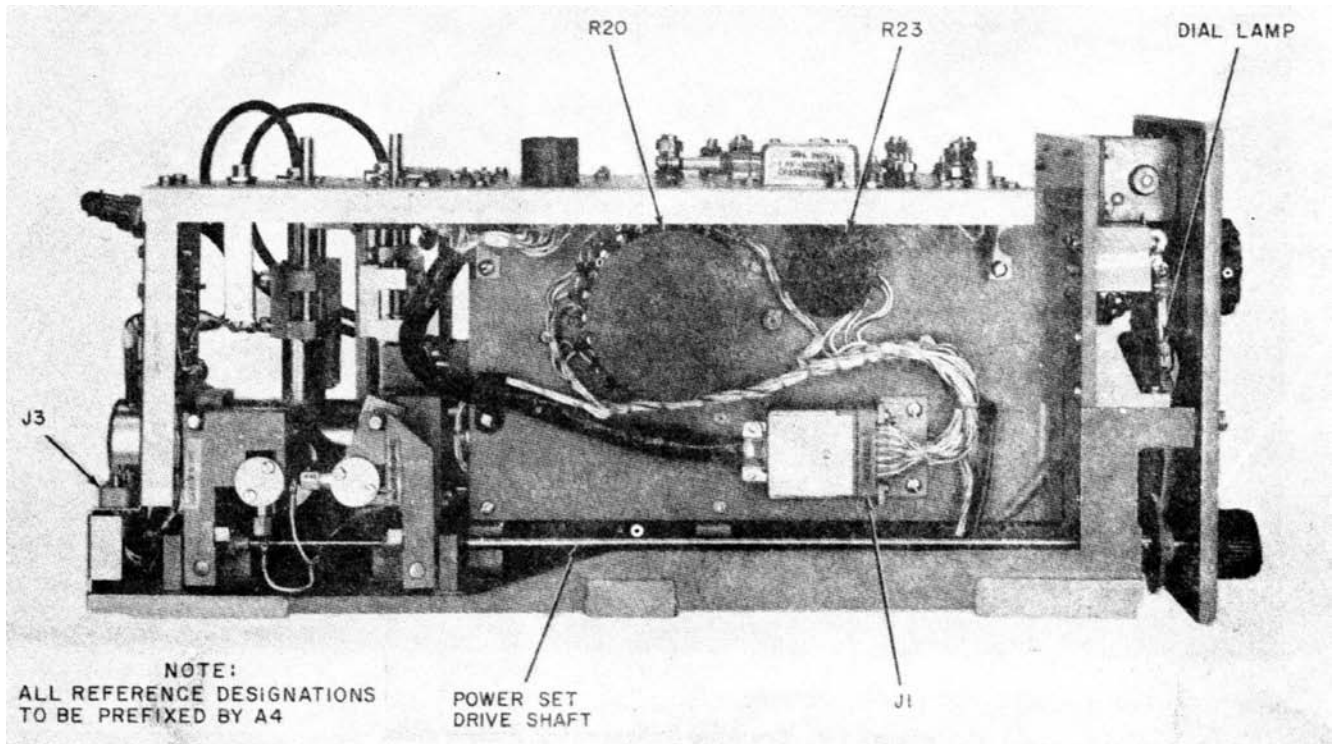
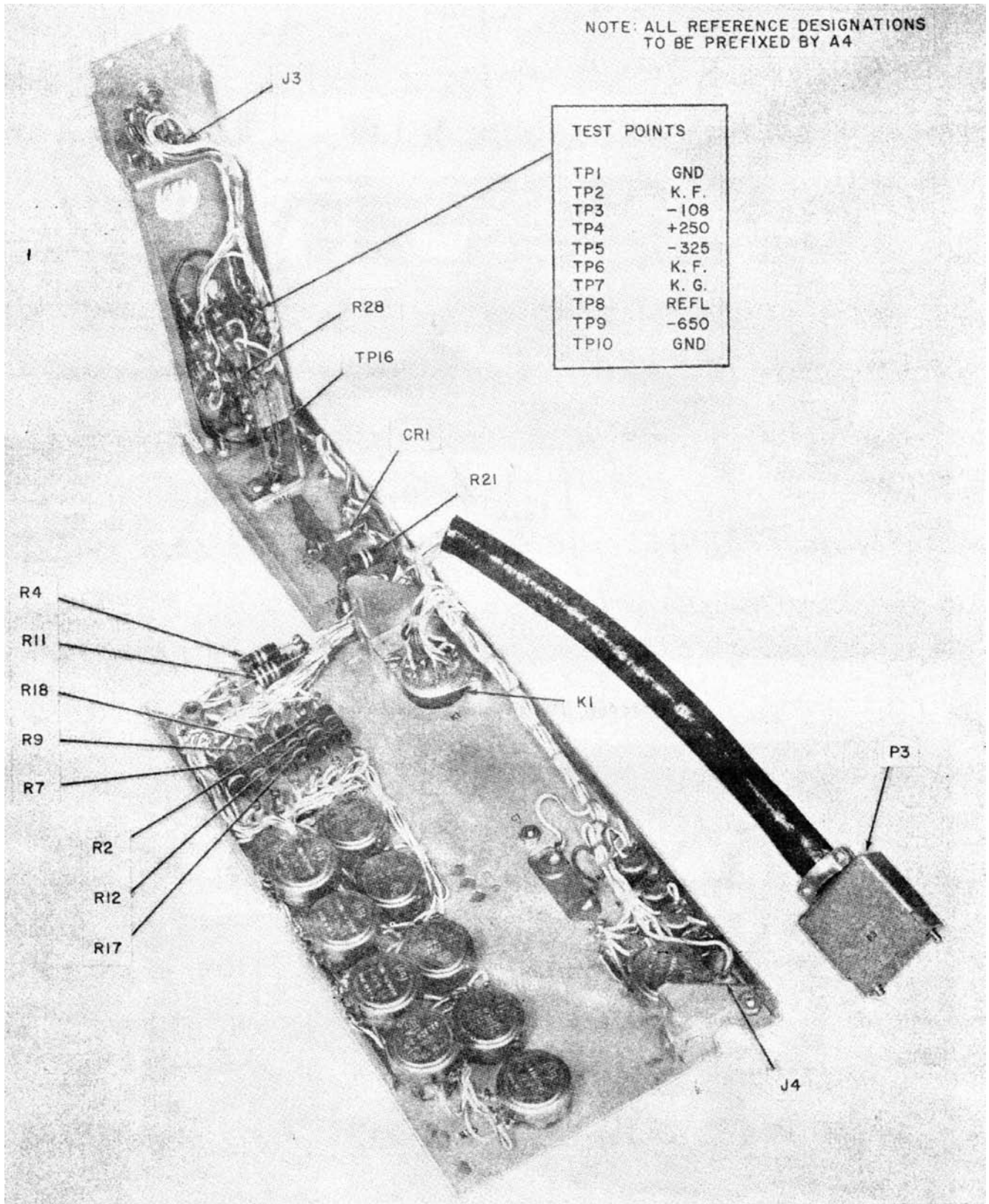

Figure 3-7. RF Oscillator Section, left side view.



EL 6625-1633-TM-45-19

Figure 3-8. Tracking Subassembly, bottom view.

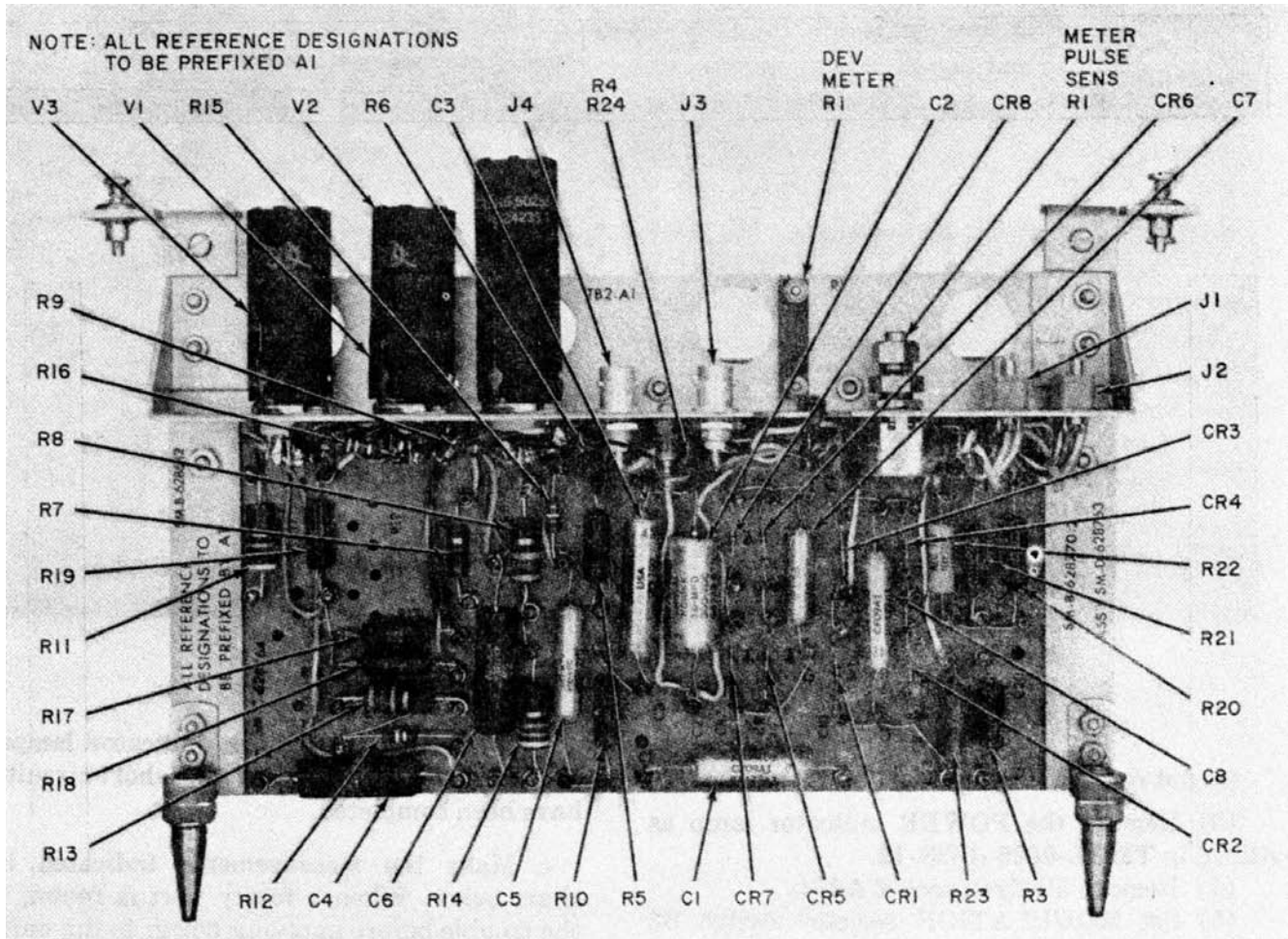

Figure 3-9. Terminal Board TB2-A1, parts location diagram.

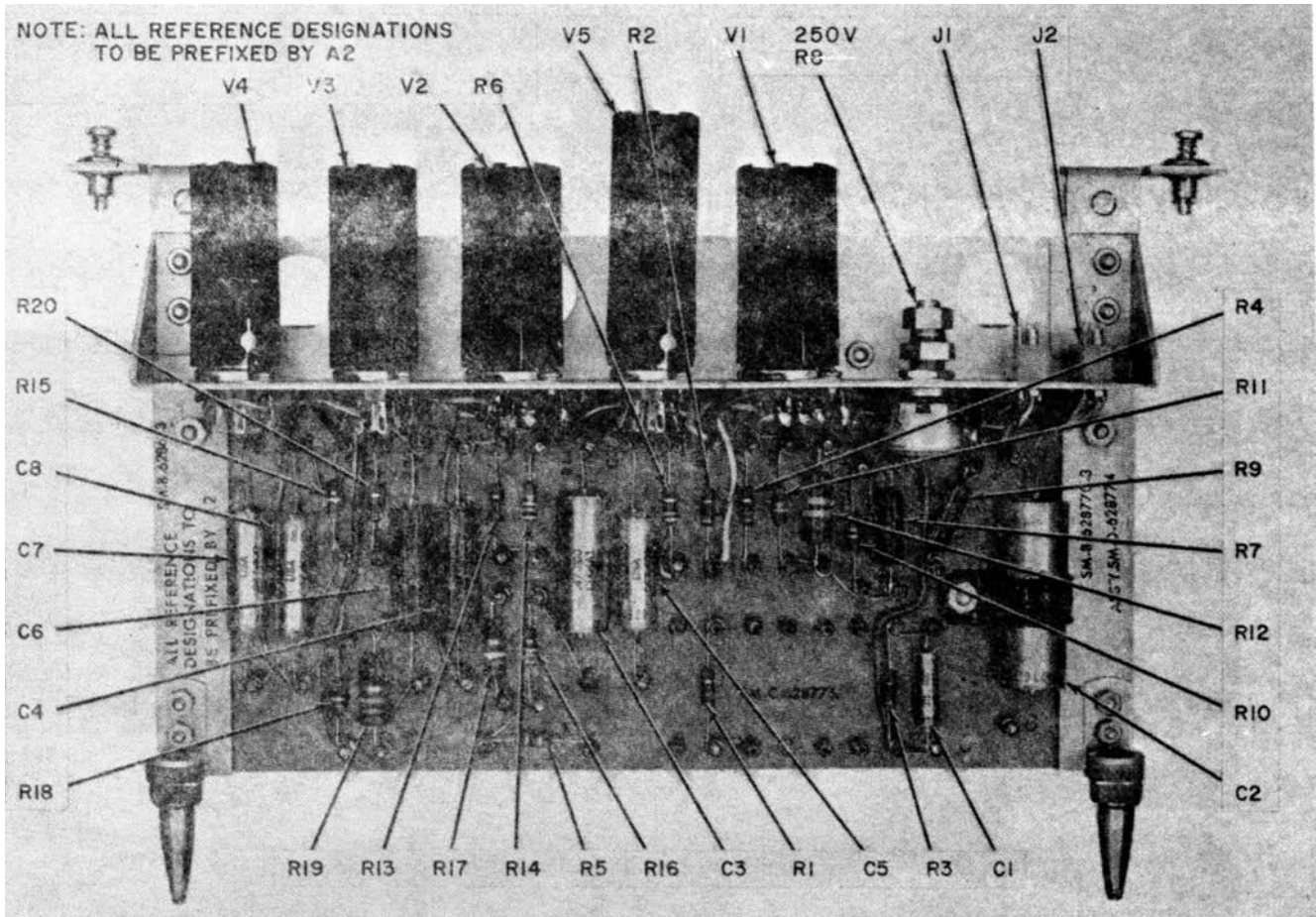

Figure 3-10. Terminal Board TB3-A2, parts location diagram.

NOTE

Do not remove the klystron.

(3) Remove the POWER indicator lamp as outlined in TM 11-6625-1633-12.

(4) Remove klystron socket A4J4.

(5) Set MODULATION selector switch S2 to OFF.

(6) Replace the tubes, indicator lamps, and the klystron socket when the short-circuit tests have been completed.

c. Make the measurements indicated in the chart below. When a faulty part is found, repair the trouble before applying power to the unit.

Short-Circuit Test Chart

<i>Point of measurement</i>	<i>Normal indication (ohms)</i>	<i>Isolating procedure</i>
Between test points A4TP1 and A4TP3 (fig. 3-8).	About 4.7K with negative probe on test point A4TP1. About 5K with negative probe on test point A4TP3.	If resistance is zero, check for shorted diodes CR20 through CR23 (fig. 3-12) or shorted transformer T3 (fig. 3-2). Replace defective component.
Between pins 2 and 4 of klystron A4V1 (fig. 5-8).	About 900 ohms	If resistance is zero, check for shorted KLY FIL potentiometer R70 (fig. 3-4); if resistance is low, check for shorted capacitor C40 or C41 or diodes CR10 through CR13. Replace defective component.
Between test point A4TP1 and pin 3 of klystron A4V1 (fig. 5-8).	About 120K	If resistance is zero, check for shorted filter capacitor C33 or C34 (fig. 3-2). Replace defective component.

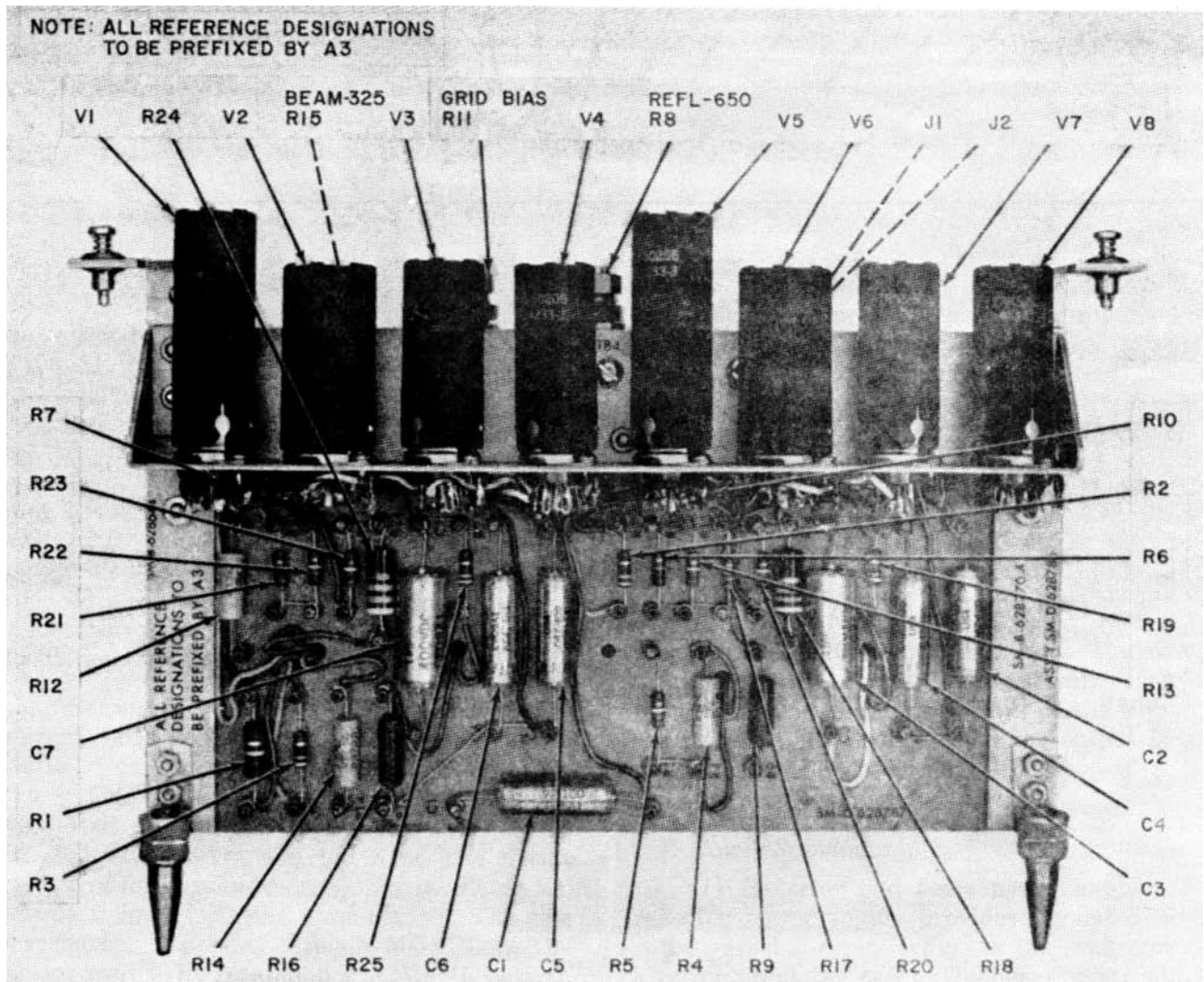

Figure 3-11. Terminal Board TB4-A3, parts location diagram.

Point of measurement	Normal indication (ohms)	Isolating procedure
Between test points A4TP1 and A4TP4 (fig. 3-8).	About 950K	If resistance is zero, check for shorted filter capacitor C45 (fig. 3-2). Replace defective component.
Between pins 1 and 3 of klystron A4V1 (fig. 5-8)	0 to 100 K depending upon adjustment of GRID BIAS potentiometer A3-R11. MODULATION selector switch S2 may be in any position except OFF.	If resistance is zero, check for shorted filter capacitor A3C1 (fig. 3-11). Replace defective component.
Between test points A4TP5 and A4TP9 (fig. 3-8).	About 26K with negative probe on test point A4TP5. About 35K with negative probe on test point A4TP9.	If resistance is zero, check for shorted filter capacitor C38; if resistance is low (about 4K), check for shorted filter capacitor C39. Replace defective component.
Between test points A4TP1 and A4TP10 (fig. 3-8).	About 140K	If resistance is zero, check for shorted filter capacitor C56 or shorted coils of relay K2, K3, or K4. Replace defective component.

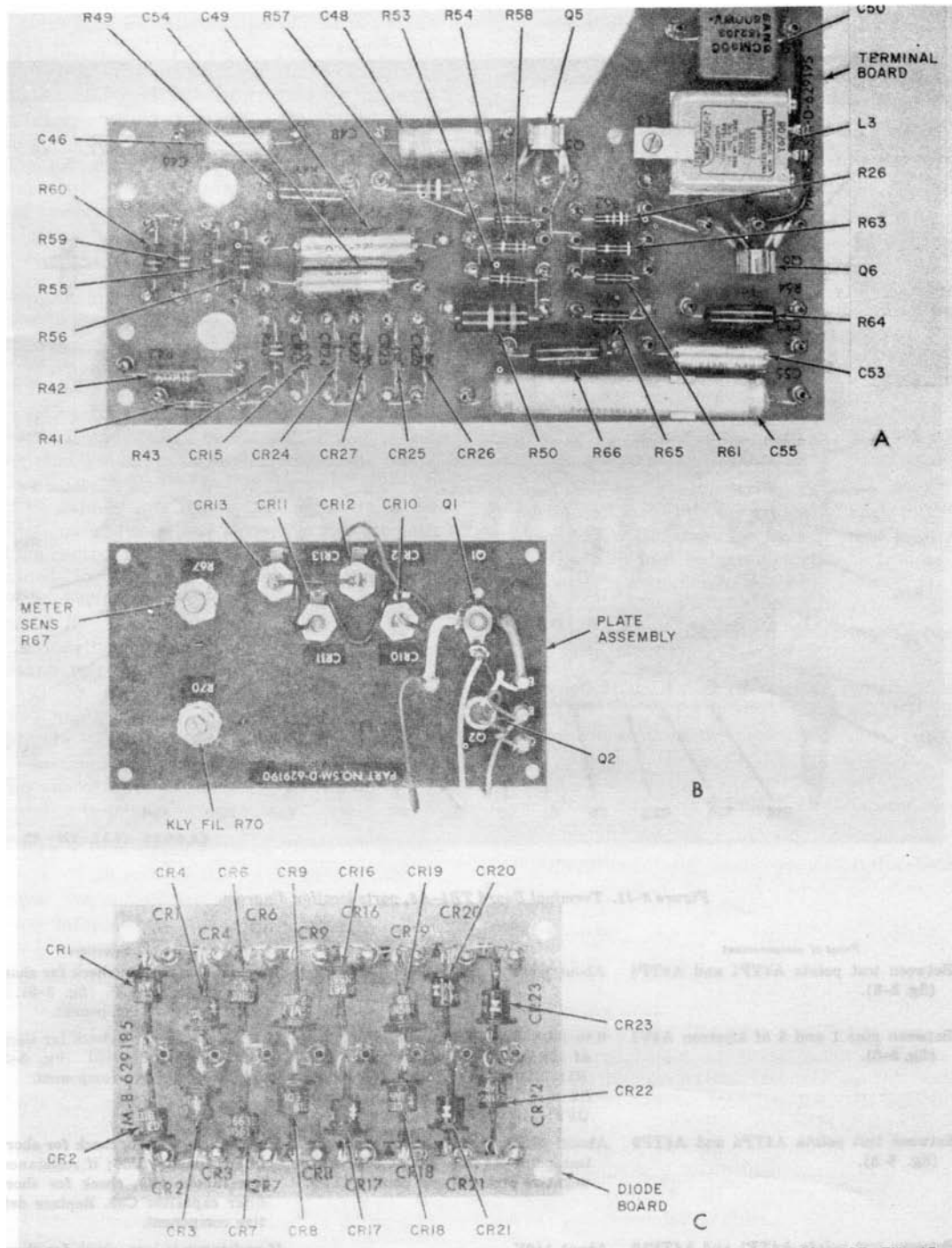

Figure 3-12. Chassis terminal boards parts location diagram.

3-5. Troubleshooting Chart

In the troubleshooting chart below, procedures are outlined for sectionalizing trouble to the power supplies, modulator, rf oscillator, or meters, and for localizing troubles to a stage within the various sections. The conditions listed in the chart are not all inclusive but are

merely a representative sample of troubles. Depending upon the nature of the operational symptoms, one or more of the localizing procedures will be necessary. When trouble has been localized to a particular stage, use voltage and resistance measurements to isolate the trouble to a particular part.

<i>Symptom</i>	<i>Probable trouble</i>	<i>Correction</i>
POWER indicator lamp DS1 does not light when POWER OFF toggle switch S8 is turned to the on position.	<ul style="list-style-type: none"> a. No ac power applied. b. Open 3 AMPS fuses F1 or F2. c. POWER indicator lamp DS1 or lamp socket defective; POWER OFF switch S8 or 115V-230V switch S9 defective; Rfi filter FL1 or FL2 defective. 	<ul style="list-style-type: none"> a. Check for input voltage. b. Replace fuse. If replaced fuse blows, check for short-circuits (para 3-4). c. Repair or replace the defective part.
Blower motor B1 does not operate.	<ul style="list-style-type: none"> a. No 115 vac power at blower motor terminals. b. Blower motor B1 defective. 	<ul style="list-style-type: none"> a. Check voltage blower motor terminals. b. Replace blower motor (fig. 3-4).
KLYSTRON indicator lamp DS2 does not light 60 seconds after POWER indicator lamp DS1 lights.	<ul style="list-style-type: none"> a. KLYSTRON indicator lamp DS2 or lamp socket defective. b. Relay supply voltage defective. c. 60 second delay relay K1 or power relay K2 defective. d. Beam power supply circuit defective. e. Shorted reflector power supply. 	<ul style="list-style-type: none"> a. Repair or replace the defective part. b. Check for 28 volts dc between test points A4TP10 and A4TP1 (fig. 3-8); remove 60 second delay relay K1; voltage between test points A4TP10 and A4TP1 should be 29.5 volts dc; if no voltage is present, check for shorted filter capacitor C56. Replace defective part. c. Connect an ohmmeter between contacts 6 and 13 of power relay K2; connect a shorting lead across contacts 3 and 4 and 8 and 9 of 60 second delay relay K1; if ohmmeter indicates a closed circuit, replace relay K1; if ohmmeter indicates an open circuit, replace relay K2. d. Check for beam supply voltage of -325 volts and adjust if necessary. e. Replace power supply.
Power set zero-set meter M2 does not indicate zero set at any position of ZERO.	<ul style="list-style-type: none"> a. Power meter bridge supply defective. 	<ul style="list-style-type: none"> a. Check for -108 volts dc between test points A4TP1 and A4TP3 (fig. 3-8). Replace power supply.
SET control knob	<ul style="list-style-type: none"> b. Power bridge circuit defective. 	<ul style="list-style-type: none"> b. Repair or replace defective parts.
Note: MODULATION selector switch S2 set at OFF position.	<ul style="list-style-type: none"> c. Power set -zero set meter M2 defective. 	<ul style="list-style-type: none"> c. Repair or replace meter.
Power set -zero set meter M2 does not indicate at red reference line for any position of POWER SET control knob.	<ul style="list-style-type: none"> a. Klystron filament power supply defective. b. Beam power supply defective. c. Reflector power supply defective. d. Beam current circuit or klystron defective. 	<ul style="list-style-type: none"> a. Repair or replace power supply. b. Replace power supply. c. Repair or replace power supply.
Note: MODULATION selector switch S2 set at CW position.	<ul style="list-style-type: none"> e. Loose gear on POWER SET control drive shaft. 	<ul style="list-style-type: none"> d. Check voltage divider capacitor A3C1, GRID BIAS potentiometer A3R11, and BEAM -325V potentiometer A3R15 (fig. 3-11). Repair or replace defective part. Replace klystron e. Tighten loose gear and perform alignment procedure.

TM 11-6625-1633-45

<i>Symptom</i>	<i>Probable trouble</i>	<i>Correction</i>
Deviation meter M1 does not indicate full scale 300KC at any position of DEVIATION control knob. Note: MODULATION selector switch S2 set at INT SINE position and DEVIATION METER RANGE selector switch S3 set at 300KC position.	<ol style="list-style-type: none">Modulation power supply or circuit defective.Modulation oscillator defective.Modulation amplifier defective.Deviation meter M1 or circuit defective	<ol style="list-style-type: none">Repair or replace power supply.Repair or replace oscillator.Repair or replace amplifier.Repair or replace defective parts.
No CW output above 825 MHz with normal output above 825 MHz.	<ol style="list-style-type: none">Low frequency probe Z1 or associated mechanical drive defective..Relay supply voltage defective or coaxial relay K4 defective.Improper adjustment of microswitch A4S1 or its cam.	<ol style="list-style-type: none">Check mechanical components; check for defective rf output cabling and check low frequency probe Z1 (fig. 3-5).Replace power supply or coaxial relay K4.Adjust or replace microswitch A4S1 (fig. 3-6).
No CW rf output above 825 MHz with normal output below 825 MHz.	<ol style="list-style-type: none">High frequency probe Z2 or associated mechanical drive defective.Relay supply voltage defective.Coaxial relay K4 defective.Improper adjustment of microswitch A4S1 or its cam.	<ol style="list-style-type: none">Check mechanical components; check for defective rf output cabling and check high frequency probe Z2 (fig. 3-5).Replace power supply.Replace coaxial relay K4.Adjust or replace microswitch A4S1 (fig. 3-6).
No CW rf output below 1060 MHz but with normal output below 1060 MHz.	<ol style="list-style-type: none">Relay A4K1 defective.Klystron tracking potentiometer. A4R20 or circuit components defective.Improper adjustment of microswitch A4S2.	<ol style="list-style-type: none">Repair or replace relay A4K1 (fig. 3-5).Check operation of potentiometer A4R20, and associated circuit resistors A4R2 through A4R7, A4R10 and A4R11 (fig. 3-5 and 3-8). Repair or replace defective parts.Adjust or replace microswitch A4S2 (fig. 3-6).
No CW rf output above 1060 MHz but with normal output below 1060 MHz.	<ol style="list-style-type: none">Relay A4K1 defective..Klystron tracking potentiometer A4R20 or circuit components defective.Improper adjustment of microswitch A4S2.	<ol style="list-style-type: none">Replace relay A4K1 (fig. 3-5).Check operation of potentiometer A4R20 and associated circuit resistors A4R8, A4R9, A4R12, through A4R19 (fig. 3-5 and 3-8); repair or replace defective parts.Adjust or replace microswitch A4S2 (fig. 3-6).
No frequency modulation of rf output Note: MODULATION switch S2 set at INT SINE position; INTERNAL MODULATION FREQUENCY selector switch S2 set at any position DEVIATION control knob set fully clockwise.	<ol style="list-style-type: none">Improper adjustment of microswitch A4S2 or its cam.Modulation power supply, modulation oscillator, modulation amplifier, and/or deviation meter defective.Relay A4K1 defective.	<ol style="list-style-type: none">Repair or replace defective parts.Check operation of relay A4K1 (fig. 3-5); check cable between connectors P13 and A4J4; check capacitor A4C1 and repair or replace defective parts.
No frequency modulation of rf output below 1060 MHz. Note: MODULATION switch S2 set at INT SINE position; INTERNAL MODULATION FREQUENCY selector switch S2 set at any position; DEVIATION control knob fully clockwise.	Relay A4K1 or resistors A4R22 through A4R28 defective.	Check operation of relay A4K1 (fig. 3-5) and repair or replace defective parts.

<i>Symptom</i>	<i>Probable trouble</i>	<i>Correction</i>
No frequency modulation of rf output above 1060 MHz. Note: MODULATION switch S2 set at INT SINE position; INTERNAL MODULATION FREQUENCY selector switch S1 set at any position; DEVIATION control knob fully clockwise.	Relay A4k1 or 1500 MC potentiometer A4R1 defective.	Check operation of relay A4K1 (fig. 3-5) and repair or replace defective parts.
No MICROVOLTS/-DBM dial rotation with ATTENUATOR control knob adjustment.	Mechanical drive loose or defective.	Check and tighten mechanical drive

3-6. Stage Gain Measurements

Use the techniques outlined in a through e below when the DEVIATION control knob can not be adjusted for a 300 KHz deviation indication on the deviation meter, or adjusted for a 300 KHz deviation of modulated rf carrier output.

- a. Connect the signal generator to the ac power source.
- b. Set the front-panel controls as indicated below:
 - (1) POWER OFF toggle switch S8 to up position.
 - (2) INTERNAL MODULATION FREQUENCY selector switch S2 to 1,000~.
 - (3) DEVIATION METER RANGE selector switch S3 to 300 KC.
 - (4) MODULATION selector switch S2 to INT SINE.
 - (5) Center frequency selector handwheel to 600.
 - (6) DEVIATION control knob fully clockwise
- c. Connect the oscilloscope between chassis ground and as directed in the test procedures.
- d. Record the oscilloscope indication for each test and determine the gain of each stage.

NOTE

Stage gain is computed by dividing the input voltage applied to the grid of the following stage by the input voltage applied to the stage under test.

- e. Stage gains are shown in the chart below; ac voltages in the chart are peak-to-peak voltages as observed on the oscilloscope.

NOTE

Excessively distorted sine waves indicate a fault in thermistor HR1. Disconnect plug P3 from jack A1J3 and measure the voltage at P3. It should be 5.6 volts peak-to-peak; if necessary, adjust 1 KC potenti-

ometer R16 to obtain 5.6 volts. Reconnect P3 to jack A1J3.

Test Connection	Peak-to-peak voltage (volts)	Stage gain
Pin 1 of V1	1.5	
Pin 1 of V2	21.0	V1 gain of 14
Pin 5 of V3	13.0	V2 gain of 0.62
Pin 1 of A1V1	1.15	
Pin 1 of A1V2	25.0	A1V1 gain of 22

3-7. Waveform Analysis

a. Waveforms may be observed at the various test jacks and at other significant points in the circuits of the signal generator by using Oscilloscope AN/USM-140. The normal waveforms obtained at the test jacks and at other significant points are either dc or pure sine waves, with the frequency determined by the position of INTERNAL MODULATION FREQUENCY switch S1, except as shown on the waveform diagram (fig. 3-13). By comparing observed waveforms with the normal waveforms, troubles can often be quickly located.

b. Before comparing the waveform with the normal waveform, carefully read the note on the waveform diagram and duplicate exactly the conditions under which the normal waveform was obtained. If an observed waveform is not a dc level, or a sine wave which closely resembles the normal waveform, trouble is indicated.

c. A departure from the normal waveform indicates trouble between the point at which the waveform is observed to be normal and the point at which the waveform is observed to be abnormal. *For example*, if a waveform is observed to be normal at the grid of a stage, and abnormal at the plate of the same stage, it is an indication that trouble is in that stage. When trouble is indicated in a stage, replace the tube before making any further tests. If replacing the tube does not correct the trouble, place the original

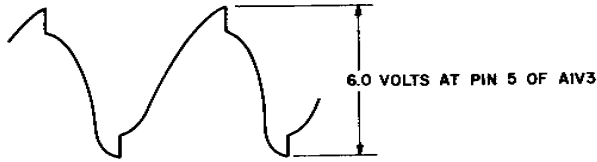

NOTE:

CONTROL	SETTING
POWER	ON(UP)
INTERNAL MODULATION FREQUENCY	1000 ~
DEVIATION METER RANGE	300KC
MODULATION	INT SINE
600-1850 FREQUENCY MC	600
DEVIATION	FULLY CLOCKWISE

EL6625-1633-45-TM -24

Figure 3-13 Normal waveform diagram.

tube back in the socket and take voltage and resistance measurements at the tube socket pins.

3-8. Isolating Trouble Within a Vacuum Tube Stage

When trouble has been localized to a tube stage, either through operational checks, short circuit tests, troubleshooting charts, stage gain measurements, or waveform analysis, use the following techniques to isolate the defective part:

- Test the tube involved, either in a tube tester or by substituting a similar type of tube which is known to be good.
- Take voltage and resistance measurements at the tube sockets (fig. 5-5.).
- Refer also to the dc resistances of transformers and coils in paragraph 3-16.
- If all checks fail to indicate a defective part, check the alignment of the signal generator.
- Use the schematic diagram (fig. 5-8) to trace circuits and to isolate the faulty part.

3-9. Isolating Trouble Within a Transistor Stage

When trouble has been localized to a transistor stage, late

the defective part by voltage measurements or resistance measurements.

CAUTION

Before attempting to perform voltage and resistance measurements, carefully follow instructions and observe notes on the voltage and resistance diagrams. Carelessness may cause additional troubles in the equipment and make the troubleshooting job more difficult. Never remove or connect a transistor with voltage applied to the circuit.

- The transistors used in the AN/URM-149 are wired into the circuit; every effort should be made to troubleshoot the equipment without physically unsoldering and removing the transistors. Paragraphs 3-10, 3-11, 3-12, and 3-14 contain information that may be helpful in isolating trouble within the transistor stages.
- If all checks fail to indicate a defective part, check the alignment of the signal generator.
- Use the schematic diagram (fig. 5-8) to trace circuits and to isolate the faulty part.

3-10. Analysis of Measurements

When measuring the resistance of circuit elements connected across the junctions of any transistor (base-emitter or base-collector), consider the polarity of the ohmmeter and try measurements with the ohmmeter connected one way, and then reverse the leads. For example, figure 3-14 shows a typical common emitter stage. If, when measuring resistor R1, the negative lead of the ohmmeter is placed at the junction of resistors R1

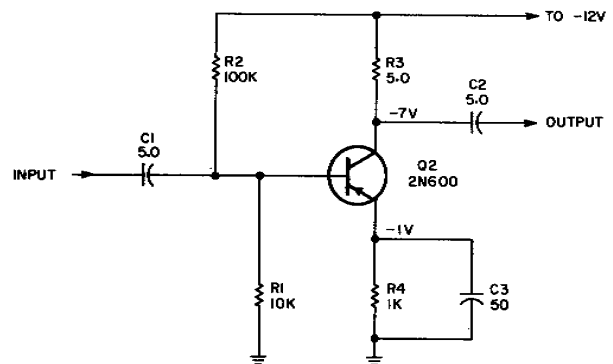

NOTE:

UNLESS OTHERWISE INDICATED, RESISTANCES ARE IN OHMS CAPACITANCES ARE IN UP,

EL6625-1633- 45-TM- 26

Figure 3-14. Typical common emitter stage.

and R2 and the positive lead is placed at ground, the ohmmeter battery forward-biases the base-emitter junction to essentially cause a short circuit between the base and emitter. This places resistor R4 in parallel with resistor R1. The ohmmeter reading in this case will be slightly less than 1,000 ohms because of the parallel resistances. If the ohmmeter leads are then reversed, the transistor will be reverse-biased, causing a very high resistance to appear between the base and the emitter. In this case, the reading would then be 10K or the value of resistor R1. If the reading is the same in both cases, the transistor is probably an open circuit or a short circuit. Also consider that different values of resistance will be obtained with the ohmmeter on different ranges. For example, if the transistor junction or a resistor plus the transistor junction is measured in the forward direction on the Rx10 range, the actual reading will be less than that if it were taken with the ohmmeter on the Rx100 range.

b. In-Circuit Transistor Resistance Chart

Transistor Number and Type	Measurements with positive ohmmeter lead connected to base				Measurements with negative ohmmeter lead connected to base			
	Emitter to base		Collector to base		Emitter to base		Collector to base	
	Resistance (Ohms)	Ohmmeter Range	Resistance (Ohms)	Ohmmeter Range	Resistance (Ohms)	Ohmmeter Range	Resistance (Ohms)	Ohmmeter Range
Q1 2N174	80	RX100	100	RX100	400	RX100	200	RX100
Q2 2N600	380	RX100	330	RX100	310	RX100	320	RX100
Q5 2N404	330	RX100	330	RX100	8,000	RX1000	10,500	RX1000
Q6 2N404	340	RX100	330	RX100	1,650	RX100	4,700	RX100

3-12. In-Circuit Transistor Resistance Checks of Module HR2

The measurements in the following chart are taken with the module connected in the equipment. Module HR2 may be removed from the circuit by removing it from its socket. Out-of-circuit tests for HR2 are given in paragraph 3-13.

Module HR2 pin to ground	Measurement with positive ohmmeter lead connected to pin		Measurement with positive ohmmeter lead connected to pin	
	Resistance (K ohms)	Ohmmeter Range	Resistance (K ohms)	Ohmmeter Range
2	250	X10,000	260	X10,000
4	250	X10,000	260	X10,000
6	250	X10,000	260	X10,000
8	250	X10,000	260	X10,000

3-13. Out-of-Circuit Tests of Module HR2

When trouble has been localized to module HR2, isolate the defective part by removing the module from its socket and making the following voltage and resistance measurements.

a. Voltage Checks at Chassis Socket of Module HR2.

3-11. In-Circuit Transistor Tests

The charts in a and b below contain voltage and resistance measurements taken with the transistors connected in the circuit. The measurements are made with Multimeter TS-352B/U.

NOTE

These readings will be valid only if the same type of ohmmeter is used and the polarity and range scales are strictly adhered to.

a. In-Circuit Transistor Voltage Chart.

Transistor Number and Type	Voltage (Volts) (All measurements indicated are with respect to ground.)		
	Emitter	Base	Collector
Q1 2N174	-290.0	-290.0	-300.0
Q2 2N600	-290.0	-290.0	-300.0
Q5 26404	0.0	-0.16	-2.05
Q6 2N404	-0.25	-0.38	-11.2

Pin to Ground	Voltage
2	-250.0
4	-270.0
6	-270.0
8	-270.0

b. Resistance Checks at Chassis Socket of Module HR2.

Pin to ground	Positive Ohmmeter lead connected to pin		Positive Ohmmeter lead connected to pin	
	Resistance (K ohms)	Ohmmeter Range	Resistance (K ohms)	Ohmmeter Range
2	250	X10,000	260	X10,000
4	250	X10,000	260	X10,000
6	250	X10,000	260	X10,000

c. Resistance Values of Module HR2

Pin to Pin	Positive ohmmeter lead connected to lower pin number		Negative Ohmmeter lead connected to pin	
	Resistance (ohms)	Ohmmeter Range	Resistance (ohms)	Ohmmeter Range
2 to 4	130 K	X10,000	1.4M	X10,000
2 to 6	1.9K	X100	10M	X10,000
2 to 8	1.7K	X100	9K	X10,000
4 to 6	200	X100	10K	X10,000
4 to 8	1.5M	X10,000	260K	X10,000
6 to 8		X10,000	12K	X10,000

3-14. Out-of-Circuit Transistor Tests

When a transistor tester is not available, an ohmmeter may be used to test the emitter and collector diode condition, maximum leakage (I_{CO}), grounded emitter and current gain do beta. Ohmmeter connections, to measure

the forward and reverse resistance of either emitter or collector diodes of the PNP transistors, are shown in figure 3-15 and in the chart below. If the ohmmeter pointer moves slowly to a lower resistance value while forward or reverse resistance measurements are being performed, the transistor is defective.

PNP transistor Number and Type	Emitter-base				Collector-base			
	Forward		Reverse		Forward		Reverse	
	Range	Reading $\pm 10\%$	Range	Reading $\pm 10\%$	Range	Reading $\pm 10\%$	Range	Reading $\pm 10\%$
Q1 (2N174)	RX100	7.5K	RX1	4	RX1	4	RX100	8K
Q2 (2N600)	RX10,000	10M	RX100	300	320	RX100	RX10,000	10M
Q3, Q4, Q5	RX10,000	7-15M	RX100	340	340	RX100	RX10,000	10-15M
Q6 (2N404)								

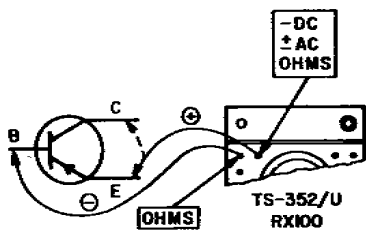

A. FORWARD EMITTER DIODE TEST

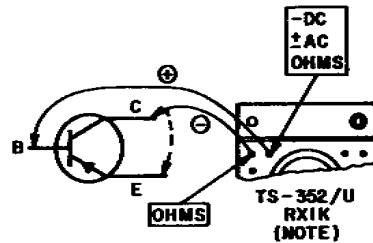

B. FORWARD COLLECTOR DIODE TEST

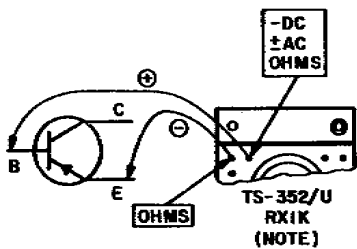

C. REVERSE EMITTER DIODE TEST

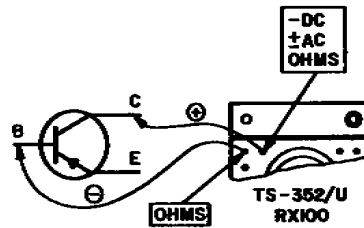

D. REVERSE COLLECTOR DIODE TEST

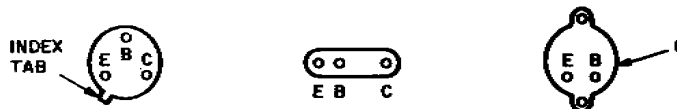

E. BOTTOM VIEW OF TRANSISTORS

EL6625-1633-45-TM-27

Figure 3-15. Transistor diode test connection diagram.

3-15. Isolating Trouble to a Diode

When trouble has been localized to a diode circuit, use the following chart to obtain the required voltage end resistance measurements.

Diode junction	Voltage (volts)	Resistance (ohms)
CR1 and CR4	80.0	0
CR3 and CR4	440.0	320K
CR2 and CR3	78.0	0
CR1 and CR2	-295.0	0
CR6 and CR9	-238.0	470K
CR8 and CR9	117.0	480K
CR7 and CR8	228.0	470K
CR6 and CR7	-600.0	460K
CR16 and CR19	278.0	900
CR18 and CR19	570.0	2,700
CR17 and CR18	270.0	900
CR16 and CR17	0.0	0
CR20 and CR23	93.0	7,000
CR22 and CR23	283.0	8,000
CR21 and CR22	93.0	7,000
CR20 and CR21	-98.0	6,000

3-16. DC Resistance and Voltage Readings of Transformers and Coils

a. The dc resistance value of transformer windings and coils in the AN/URM-149 are listed in the chart below:

Transformer or coil	Terminals	Resistance (ohms)
T1	1-2	8
	3-4	8.7
	5-6	140
	7-8	1.25
	9-10	less than 1

Transformer or coil	Terminals	Resistance (ohms)
T2	1-2	7.25
	3-4	7.8
	5-6	150
	7-8	less than 1
	9-10	less than 1
T3	1-2	3.5
	3-4	3.8
	5-6	37
	7-8	48
	9-10	less than 1
T4	11-12	less than 1
	12-13	less than 1
	1-3	greater than 30
	4-5	25
	6-7	26
L1	1-2	210
	3-4	275
L2	1-2	220
L3	1-2	17.5

b. The open circuit transformer output voltages with 115 vac line input voltage, are shown in the chart below:

Transformer	Terminals	Voltage (volts)
T1	5-6	470.0
	7-8	30.5
	9-10	6.4
T2	5-6	470.0
	7-8	15.5
	9-10	6.4
	11-12	6.4
T3	5-6	380.0
	7-8	250.0
	9-10	6.4
	11-13	6.4

CHAPTER 4

REPAIRS AND ADJUSTMENTS

Section I. REPAIRS

4-1. General Parts Replacement Techniques

a. Most of the parts of the signal generator can be reached and replaced easily without special procedures. The tube sockets, capacitors, filter chokes, and inductors are mounted securely to the chassis with hexagonal nuts or binding head screws.

b. The power transformers are bolted to the chassis. The nuts securing the transformers can easily be removed with a socket wrench. The dial knobs are removed with Allen wrenches. The thermistor covers are removed by loosening the two screws on the cover plate.

c. If any of the wafer switches or potentiometers require replacement, carefully tag the wires or sketch the connections to avoid misconnection when the new component is installed. Follow this practice whenever replacement requires the disconnection of numerous wires.

d. Be very careful when replacing transistors in the AN/URM-149. Use a pencil-type soldering iron with a 25-watt maximum capacity. Some circuits of the signal generator are transistorized. If the soldering iron must be connected to an ac power source, use an isolating power transformer between the iron and the ac power line. Do *not* use a soldering gun; it may induce damaging voltages in components.

e. When soldering transistor leads, solder quickly. Where wiring permits, use a heat sink (such as long-nose pliers) between the soldered joint and the transistor. Use approximately the same length and dress of transistor leads as used originally. For additional techniques of soldering refer to TB SIG 222.

4-2. Removal and Replacement of RF Oscillator Section

The rf oscillator section is mounted on the right side of the main chassis as shown in figure 3-10.

To remove the rf oscillator section, proceed as follows:

a. Disconnect plug P8 and coaxial connectors P14, A4P1, and A4P2.

NOTE

Coaxial connectors A4P1 and A4P2 are connected to coaxial relay K4 which is mounted on the front panel.

b. Rotate the ATTENUATOR control knob for an indication of approximately -80 dbm (to provide clearance for gear train components).

c. Remove the four hexagonal screws located at each rf oscillator section support.

d. Push the rf oscillator section far enough forward so that it may be grasped from the front.

e. Pull the rf section away from the front panel.

NOTE

Do not allow the attenuator-probe cables to be crushed against the frame of the main chassis during removal.

f. Replace the rf oscillator section by sliding the rf oscillator section on to its supports in the main chassis.

g. Insert the four screws through each support and the rf oscillator section.

h. Connect plug P8 and coaxial connectors, P14, A1P1, and A1P4.

NOTE

The tracking subassembly must be removed from the rf oscillator section chassis to replace most of its components or tracking potentiometer A4R20 or A4R23. When a tracking adjustment potentiometer of fixed resistor is replaced, perform the alignment procedures given in paragraph 4-18.

i. When the rf oscillator section is removed (*a*

above) the tracking subassembly can be disassembled. Refer to figures 3-5 and 3-7, and proceed as follows:

- (1) Disconnect connectors P3 from coaxial connector A4P1 and coaxial connector P4 from jack A4J3.
- (2) Remove the mounting screws and nuts and lift the tracking assembly partially away from the rf oscillator section.

NOTE

Perform the adjustment procedures given in paragraphs 4-16 and 4-17 if the replaced component is in the modulation tracking circuit or the alignment procedure in paragraph 5-8 if the replaced component is in the repeller tracking circuit.

4-3. Removal and Replacement of Terminal Boards

(fig. 3-1)

a. The AN/URM-149 contains plug-in terminal boards TB2-A1, TB3-A2, and TB4-A3 and fixed terminal board TB1. *Terminal board TB1 is bolted to the main chassis and should not be removed.* The plug-in terminal boards can be removed from replacement or servicing by disconnecting the cable connectors, unlocking the two cam locks and lifting the boards straight up

NOTE

Make sure to connect the proper plugs and jacks when replacing the terminal boards.

4-4. Removal and Replacement of Tracking Potentiometers A4R20 and A4R23

(fig. 4-1)

a. Remove a tracking potentiometer as follows:

- (1) Remove the rf oscillator section and the tracking subassembly (para 4-2).
- (2) Carefully sketch or tag the connections to the potentiometer being replaced and unsolder the leads.
- (3) Loosen the associated driver-gear set screws. If necessary, rotate the center frequency selector hand-wheel until the set screws are accessible.
- (4) Rotate the center frequency selector hand-wheel until the mounting screws on potentiometer A4R20 or the one-half inch mounting nut on potentiometer A4R23 are accessible.
- (5) Remove the mounting hardware and pull the potentiometer away from the potentiometer plate assembly.

b. Replace the tracking potentiometer as follows:

- (1) Mount the potentiometer in the same manner as the original.

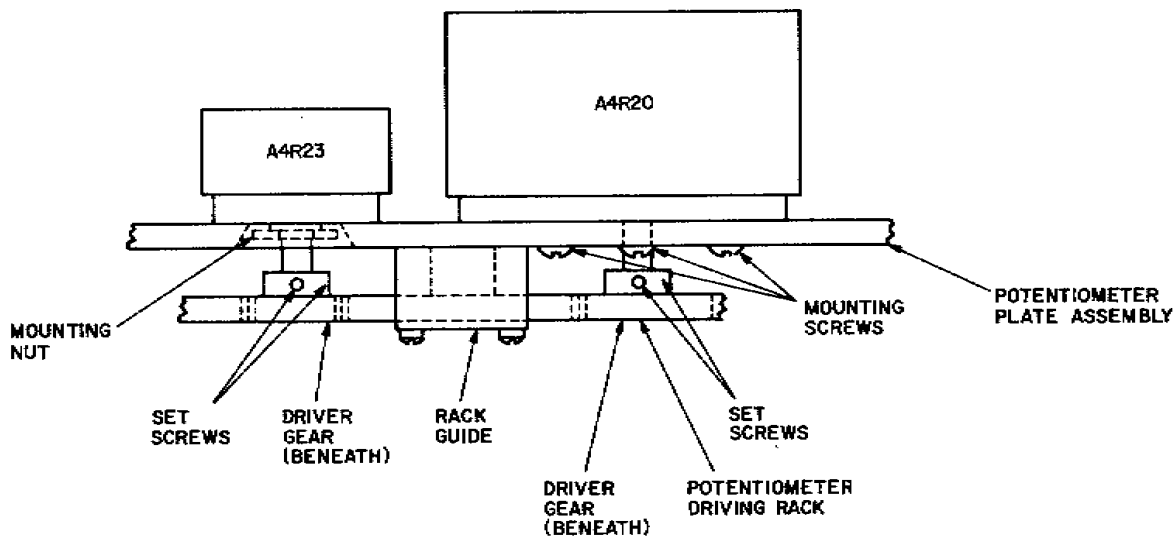

NOTE:

PARTIAL TOP VIEW OF RF OSCILLATOR SECTION WITH TRACKING SUBASSEMBLY REMOVED

Figure 4-1. Tracking potentiometers A4R20 and A4R23, mounting details.

NOTE

Do not tighten the two set screws holding the driver gear.

(2) Rotate the center frequency selector handwheel until the 600-1850 MC FREQUENCY MC counter indicates the lowest possible frequency.

(3) Use the multimeter as an ohmmeter and connect the leads between pins 2 and 3 of the potentiometer.

(4) Rotate the potentiometer drive shaft until the multimeter indicates approximately 50ohms.

(5) Tighten the two set screws holding the driver gear, without shifting the potentiometer drive shaft.

(6) Disconnect the multimeter.

(7) Assemble the tracking subassembly to the rf oscillator section (para 4-2).

(8) Perform the adjustment and alignment procedures given in paragraphs 4-16, 4-17, 4-18 and 5-8.

4-5. Removal and Replacement of Thermistor A4RT2 and A4RT3

a. To remove either thermistor, proceed as follows:

(1) Remove the rf oscillator section (para 4 - 2).

(2) Remove the two screws holding the rack guide.

(3) Lift the rack and ease the thermistor yoke away from the rf oscillator section.

(4) Note the position of the thermistor loop relative to the cavity.

(5) Note the position of the leaf spring which holds the thermistor coupling pressed against the yoke.

(6) Slide the thermistor coupling out of the yoke.

(7) Remove the two cover screws and the coupling cover.

(8) Note the position of the thermistor loop with respect to capacitors A4C2 and A4C3.

(9) Unsolder the connection between the center conductor and the capacitor.

(10) Loosen the two set screws holding the coupling and pull the coupling away from the thermistor probe.

(11) Note the exact shape and size of the loop.

(12) Unsolder and remove the thermistor.

b. Replace the thermistor as follows:

(1) Form the shape and size of the loop as noted in a(11) above.

(2) Solder the new thermistor and assemble the probe.

(3) Insert the thermistor probe into the coupling in the position noted in a(8) above.

(4) Tighten the two set screws.

(5) Solder the center conductor to the capacitor.

(6) Replace the coupling cover.

(7) Slide the coupling into the yoke leaf springs.

(8) Assemble the thermistor yoke to the rf oscillator section.

CAUTION

Be careful not to distort the loop by pushing the yoke all the way into the cavity.

4-6. Removal and Replacement of Attenuator Probes

(fig. 3-5)

a. To remove the low or high frequency attenuator probes Z1 and Z2 proceed as follows:

(1) Remove the rf oscillator section (para 4-2).

(2) Loosen the two set screws on the coupling.

(3) Lift the attenuator probe up.

b. Replace the attenuator probes as follows:

(1) Insert the attenuator probe in the coupling.

(2) Rotate the probe until the vertical scribe mark faces the rear of the rf oscillator section.

(3) Tighten the coupling setscrews.

4-7. Removal and Replacement of Microswitch A4S1 and A4S2

(fig. 3-6)

a. To remove either microswitch, proceed as follows:

(1) Rotate the center frequency selector handwheel to set the 600-1850 MC FREQUENCY MC counter at 600 MHz

(2) Carefully sketch or tag the connections to the two switches and unsolder them.

(3) Remove the two mounting screws through the top of switch A4S2 and remove the two switches.

b. Replace the microswitch as follows:

(1) Replace the defective microswitch and mount the two switches by means of the two mounting screws.

(2) Solder the connections indicated by the tags or sketch made in *a* (2) above.

(3) Loosen the binding head screw on the attenuator closest to switch A4S1.

(4) Rotate the counter frequency selector handwheel for a frequency indication of 845 MHz.

(5) Loosen the second binding head screw on the attenuator cam and adjust the cam to just trip switch A4S1.

(6) Tighten the second binding head screw.

(7) Rotate the center frequency selector handwheel for a frequency indication of 600 MHz.

(8) Tighten the first binding head screw.

(9) Check that switch A4S1 is activated between 840 and 845 MHz.

(10) Loosen the binding head screws on the mode cam.

(11) Rotate the center frequency selector handwheel for a frequency indication of 1067 MHz.

(12) Adjust the mode cam to just trip switch A4S2.

(13) Tighten the binding head screws.

(14) Check that switch A4S2 is activated between 1065 and 1070 MHz.

4-8. Replacement of Tape Cam

A worn tape cam may be replaced by removing the screw at one end and unhooking the spring at the other. The replacement is fastened by hooking the spring to one end of the tape cam and screwing down the other end.

4-9. Replacement of Frequency Travel Stop Screws

The low and high frequency travel stop screws are shown in figure 3-6. To replace either stop screw, proceed as follows:

a. *Removal of Low Frequency Travel Stop Screw.*

(1) Remove the rf oscillator section (para 4-2).

(2) Remove the POWER SET and ATTENUATOR control knob by loosening the set screws and pulling the knobs away from the front panel.

(3) Remove the -center frequency selector handwheel by loosening the two set screws and pulling the handwheel away from the front panel.

NOTE

To make these set screws accessible it may be necessary to adjust the handwheel until the 600-1850 MC FREQUENCY MC counter indicates 592 MHz. Then slip the clutch inside the handwheel until the set screws become accessible. The clutch is slipped by continuing the rotation of the handwheel after the stop is reached.

(4) Remove the three binding head screws holding the rf oscillator section front panel.

(5) Remove the rf oscillator section front

(6) Loosen the low frequency stop screw locknut and remove the stop screw.

b. *Replacement of Low Frequency Travel Stop Screw.*

(1) Temporarily reassemble the center frequency selector handwheel and tighten the set screws.

(2) Rotate the center frequency selector handwheel for a frequency indication of 592 MHz.

(3) Insert the stop screw, lockwasher and locknut until the screw is stopped by the carriage.

(4) Tighten the locknut.

(5) Remove the center frequency selector handwheel.

(6) Reassemble the rf oscillator section front panel and tighten the three binding head screws.

CAUTION

Make sure that the three shafts are free to rotate.

(7) Reassemble the two knobs and the hand

c. *Removal of High Frequency Travel Stop Screw.*

- (1) Loosen the high frequency stop screw locknut.
- (2) Remove the stop screw.

d. Replacement of High Frequency Travel Stop Screw.

- (1) Rotate the center frequency selector handwheel for a frequency indication of 1862 MHz.
- (2) Insert the stop screw with lockwasher and locknut until the screw is stopped by the carriage.
- (3) Tighten the locknut.

4-10. Replacement of Frequency Tracking Springs

The two frequency tracking springs are connected to the yoke which drives the rf choke. To replace the springs, proceed as follows:

a. Removal.

- (1) Rotate the center frequency selector handwheel for an indication of 1000 MHz.
- (2) Unhook one end of the spring from the yoke and push the spring out of the cavity block.
- (3) Unhook the other end of the spring from the hook and plate.

b. Replacement.

- (1) Fasten one end of the spring to the hook and plate.
- (2) Push the spring through the cavity in the block.
- (3) Stretch the spring away from the block and hook the end to the eye coupling on the yoke.

4-11. Replacement of Coaxial Relay K4

a. To remove the coaxial relay, proceed as follows:

- (1) Remove the rf oscillator section (para 4-2).
- (2) Remove the two screws holding the rf oscillator support tray closest to the front panel (fig. 3-3) and remove the tray.
- (3) Unsolder and tag the leads to the relay coil.
- (4) Remove the four mounting screws grouped about RF OUTPUT jack J5 on the front panel and remove the coaxial relay.

b. Replace the relay as follows:

- (1) Mount the relay and install the four mounting screws.
- (2) Solder the leads to the relay coil.
- (3) Mount the tray and install the two screws.
- (4) Reassemble the rf oscillator section (para 4-2) .

Section II. ADJUSTMENT PROCEDURES

4-12. Test Equipment and Special Tools Required for Adjustment

The following test equipment and special tools are required for adjustment of the signal generator.

- a.* Multimeter TS-352B/U.
- b.* Differential Voltmeter DC ME-202.
- c.* Oscilloscope AN/USM-140.
- d.* Wattmeter AN/URM-98.
- e.* Frequency Meter TS-186/UP.
- f.* Modulation Meter, ME-57/U.
- g.* Spectrum Analyzer TS-723D/U.

h. Electronic Voltmeter AN/URM-145.

i. Electronic Tool Kit TK-100/G.

4-13. Power Supply Voltage Adjustments

a. Connect the test equipment input terminals between the test points indicated in the chart below. Use the least sensitive scale range available prior to taking measurements to avoid overloading the test equipment.

NOTE

All measurements and adjustments are made with Differential Voltmeter ME202.

b. Connect the signal generator to a power source. Set the POWER OFF toggle switch to the up position and allow the unit to warm up for 15 minutes.

Power Supply Voltage Adjustment Chart

Signal generator test points	Performance standard	Adjustment	Procedure
A4TP2 A4TP6	6.1 to 6.5 vac	KLY Fil potentiometer R70	Adjust KLY FIL potentiometer R70 (fig 3-4) for a 6.3 volt indication of ME-202.
A4TP5 A4TP1	-322 to - 328 vdc	BEAM-325 potentiometer A3R15	Adjust BEAM-325 potentiometer A3R15- (fig. 3-3) for a 325 volt dc indication ME-202.
A4TP9 A4TP1	-644 to -656 vdc	REFL-650 potentiometer A3R8	Adjust REFL-650 potentiometer A3R8 (fig. 3-3) for a -650 volt dc indication on ME-202.
A4TP4 A4TP1	284 to 252 vdc	250V potentiometer A2R8	Adjust 250V potentiometer A2R8 (fig 3-10) for a 250 volt dc indication ME-202

4-14. Klystron Beam Current Adjustment

a. Connect the AN/URM-98 to the signal generator RF OUTPUT jack J5.

b. Connect the signal generator to a power source and set the controls to the positions below:

NOTE

Allow the signal generator to warm up for 15 minutes.

(1) 600-1850 MC FREQUENCY MC counter to 600.

(2) ATTENUATOR control knob fully clockwise.

(3) POWER OFF toggle switch to up.

c. Adjust GRID BIAS potentiometer A3R11 (fig. 3-1) for a maximum power output indication on the wattmeter.

4-15. Power Monitor Bridge Adjustment

a. Remove the rf oscillator section (para 4-2).

b. With the rf oscillator section removed, reconnect connector P8 to jack A4J3.

c. Connect the signal generator to a power source and set the controls to the positions listed below:

NOTE

Allow the signal generator to warm up for 15 minutes.

(1) Center frequency selector handwheel to 700.

(2) MODULATION selector switch to OFF.

(3) POWER OFF toggle switch to up.

d. Connect the AN/URM-145 between capacitor A4C3 and ground.

e. Adjust ZERO SET control knob and METER SENSITIVITY potentiometer R67 (fig. 3-1) for a simultaneous indication of 0.39 volt rms on the AN/URM-145 and zero set on the power set meter.

f. Set POWER toggle switch to OFF position. Disconnect the AN/URM-145 and reassemble rf oscillator section (para 4-2).

4-16. Modulation Frequency Adjustments

a. Disconnect connector P13 from jack A1J4.

b. Connect the frequency meter input to jack A1J4 (fig. 3-9).

c. Connect the signal generator to a power source and set the controls to the position listed below:

NOTE

Allow the signal generator to warm up for 15 minutes.

(1) MODULATION selector switch to INT SINE.

(2) DEVIATION control knob fully clockwise.

(3) DEVIATION METER RANGE selector switch to 300 KC.

(4) Power OFF toggle switch to up.

d. Set the INTERNAL MODULATION FREQUENCY selector switch to the positions indicated in the following chart and make the trimmer capacitor adjustments shown to obtain frequency meter indications within the limits specified.

<i>INTERNAL MODULATION FREQUENCY switch position</i>	<i>Trimmer capacitor adjustment</i>	<i>Frequency meter indication (Hz)</i>
1000~	C1	990 to 1010
1600~	C5	1584 to 1616
20KC	C9	19,800 to 20,200
68KC	C13	67,320 to 68,680
108KC	C17	106,920 to 109,080

e. Disconnect the test equipment and reconnect connector P13 to jack A1J4.

4-17. Modulation Oscillator Output Adjustment

a. Disconnect connector P3 from jack A1J3 (fig. 3-9) and connect the AN/USM-140 input to connector P3.

b. Connect the signal generator to a power source and set the controls to the positions listed below:

NOTE

Allow the signal generator to warm up for 15 minutes.

- (1) MODULATION selector switch to INT SINE.
- (2) DEVIATION control knob fully clockwise.
- (3) POWER OFF toggle switch to up.

c. Set the INTERNAL MODULATION FREQUENCY selector switch to positions indicated in the following chart and make the adjustments shown to obtain the approximate peak-to-peak voltages indicated on the oscilloscope.

<i>INTERNAL MODULATION FREQUENCY switch position</i>	<i>Adjustment potentiometer</i>	<i>Oscilloscope peak-to-peak voltage indications (volts)</i>
1000~	R16	5.6
1600~	R18	5.6
20KC	R19	5.6
68KC	R20	5.6
108KC	R21	5.6

d. Disconnect the test equipment and reconnect connector P3 to jack A1J3.

4-18. Deviation Meter Adjustment

a. Connect the signal generator to a power source and set the controls to the positions listed below:

NOTE

Allow the signal generator to warm up for 30 minutes.

- (1) MODULATION selector switch to INT SINE.
- (2) DEVIATION control knob fully clockwise.

(3) DEVIATION METER RANGE selector switch to 300 KC.

(4) INTERNAL MODULATION FREQUENCY to 1000 ~.

(5) POWER OFF toggle switch to up.

b. Adjust deviation meter adjustment potentiometer AIR1 (fig. 3-9) to position the pointer of deviation meter M1 against the right hand stop post.

4-19. Deviation Accuracy Adjustments

a. Connect the input of the TS-723D/U to the signal generator RF OUTPUT connector J5.

b. Connect the signal generator to a power source and set the controls as indicated below:

NOTE

Allow the unit to warm up for 30 minutes.

(1) DEVIATION METER RANGE selector switch to 300 KC.

(2) INTERNAL MODULATION FREQUENCY to 108 KC.

(3) POWER OFF toggle switch to up.

c. Set the center frequency selector handwheel for an indication of 600 MHz.

d. Set MODULATION selector switch to OFF and adjust ZERO SET control knob for a zero set indication on the power set meter.

e. Set MODULATION selector switch to CW.

f. Adjust POWER SET control knob for a power set meter indication as the red reference line.

CAUTION

Do not perform adjustments if indication is within specified limits.

g. Tune the TS-723D/U to place signal display at the center of the screen.

h. Adjust RF OUTPUT control for a convenient spectrum analyzer display height.

i.. Set MODULATION selector switch to INT SINE.

j. Adjust the DEVIATION control knob until a carrier null is displayed on the TS-723D/U.

k. Observe that the deviation meter indicates between 208 and 312 KHz.

TM 11-6625-1633-45

l. Adjust 600 MC potentiometer A4R27 (fig. 3-5) for a nominal 260 KHz indication on the deviation meter at carrier null.

m. Repeat the procedure outlined in *c* through *f* above with 600-1850 MC FREQUENCY MC counter set at 1000 MHz.

n. Repeat the procedure in *m* above, except adjust 1000 MC potentiometer A4R22.

o. Repeat the procedure in *c* through *f* above with 600-1850 MC FREQUENCY MC counter set at 1500 MHz.

p. Repeat the procedure in *o* above, except adjust 1500 MC potentiometer A4R1.

q. Repeat the procedure in *c* through *f* above with 600-1850 MC FREQUENCY MC control set at 700 MHz.

r. Repeat the procedure in *q* above, except adjust 700 MC potentiometer A4R26.

s. If the 700 MC potentiometer A4R26 cannot be adjusted to obtain a deviation meter indication between 208 and 312 KHz, readjust 600 MC potentiometer A4R27 until the first carrier null is obtained for a deviation meter indication between 208 and 312 KHz at 600 and 700 MHz.

t. Repeat the procedure in *c* through *f* above with -

600-1850-MC FREQUENCY MC counter set at 800 MHz.

u. Repeat the procedure in *g* through *l* above, except adjust 800 MC potentiometer A4R25.

v. If the 800 MC potentiometer A4R25 cannot be adjusted to obtain a deviation meter indication between 208 and 312 KHz for a carrier null, readjust the 600 MC potentiometer A4R27, the 700 MC potentiometer A4R26, and the 800 MC potentiometer A4R25 until the first carrier null indication is obtained for a deviation meter indication between 208 and 312 KHz at 600, 700, and 800 MHz.

w. Repeat the procedure in *c* through *f* above with 600-1850 MC FREQUENCY MC counter set at 900 MHz.

x. Repeat the procedure in *g* through *l* above, except adjust 900 MC potentiometer A4R24.

y. If the 900 MC potentiometer A4R24 cannot be adjusted to obtain a deviation meter indication between 208 and 312 KHz for a carrier null, readjust the 600 MC potentiometer A4R27, 700 MC potentiometer A4R26, 800 MC potentiometer A4R25, 900 MC potentiometer A4R24, and 1000 MC potentiometer A4R22 until the first carrier null indication is obtained for a deviation meter indication between 208 and 312 KHz at 600, 700, 800, 900, and 1000 MHz.

z. Repeat the procedure in *y* above until no further adjustments are required.

CHAPTER 5

DEPOT MAINTENANCE AND DEPOT OVERHAUL STANDARDS

Section I. DEPOT MAINTENANCE

5-1. General

Complete rebuild of the AN/URM-149 and/or its individual components may be accomplished by depot maintenance facilities when authorized.

Restore the appearance, performance, and life expectancy of the AN/URM-149 to a standard comparable to that of new equipment by performing the following procedures:

- a. Disassemble the unit as required.
- b. Inspect all component parts of the AN/ URM-149.
- c. Repair or replace any worn or unserviceable part with a part that conforms to the original manufacturing specifications and tolerances.

d. Reassemble the unit.

e. Perform an operational test of the equipment.

5-2. Maintenance Procedures

Rebuild procedures of the AN/URM-149 will include all repairs, rebuild, replacement, and testing operations necessary to make the equipment suitable for return to the Department of the Army supply system stocks for reissue to using organizations. Detailed procedures for accomplishing the repair and adjustments established in the preceding portions of this manual and such additional repair and rebuild operations as deemed necessary will be established by the maintenance facility performing the work.

Section II. DEPOT OVERHAUL STANDARDS

5-3. Applicability of Depot Overhaul Standards

The tests outlined in this section are designed to measure the performance capability of repaired components that comprise the AN/URM-149. Because there are alternate methods to virtually every type of operation, it must not be presumed that the tests described will be satisfactory for complete acceptance of the equipment. Rather, it is the purpose to merely offer assistance and guidance in the most expedient method of determining that the AN/URM-149 meets the minimum acceptable limit of system performance.

5-4. Applicable References

a. Technical publications applicable to the AN/ URM-149 are listed in Appendix A. Applicable procedures and standards of the depots performing these tests form a part of the requirements for testing this equipment.

b. Perform all applicable MWO's pertaining to the equipment before making the tests specified. DA Pam 310-7 lists all current MWO's.

5-5. Physical Tests and Inspections

a. Inspect the front panel for damaged, loose, or missing screws, knobs, or other parts. There should be no evidence of damage or loose components.

b. Inspect the chassis for signs of excessive wear or damage, missing components, or hardware.

c. Inspect the condition of finish. Check for rust and corrosion. The external surfaces should not show bare metal and all front panel lettering should be legible.

NOTE

Touchup painting is recommended instead of refinishing. Screwheads and receptacles should not be polished with abrasives

5-6. Test Equipment and Additional Equipment Required for Depot Maintenance

All test equipment and additional equipment required to perform the testing procedures given in this section are listed below and are authorized under TA 11-17, Army Field Maintenance Shops, and TA 11-100 (11-17), Allowances of Army Corps Expendable Supplies for Army Field Maintenance Shop, Continental United States.

- a. Multimeter TS-352B/U.
- b. Wattmeter AN/URM-98.
- c. Frequency Meter TS-186D/UP.
- d. Modulation Meter, ME-57/U.
- e. Spectrum Analyzer TS-723D/U.
- f. Differential Voltmeter ME-202.
- g. Oscilloscope AN/USM-140.
- h. Electronic Voltmeter AN/URM-145.
- i. Ballantine Model 320 RMS Voltmeter.
- j. Allison Labs Model 2AB Filter.
- k. Electronic Equipment Tool Kit TK-100/G.

5-7. Replacement of Klystron

(fig. 3-6)

- a. To remove the klystron, proceed as follows:

WARNING

After a few minutes of operation the klystron tube socket becomes extremely hot. Do not touch it with bare hands.

- (1) Loosen the clamp on the rear of the cavity, and pull the klystron tube cover straight back.
- (2) Pull the cover plugs straight out.
- (3) Loosen the klystron retaining nut with a spanner wrench.
- (4) Pull the klystron straight back with a slight twisting motion.

- b. Replace the klystron as follows:

NOTE

Insure that the klystron is firmly seated in its cavity.

- (1) Insert the klystron into its socket.
- (2) Tighten the klystron retaining nut with a spanner wrench.
- (3) Connect the cover plug.
- (4) Install the klystron tube cover and attach and tighten the clamp.
- (5) Perform the klystron alignment procedure (para 5-8), the rf output power adjustments (para 5-9),

and the deviation accuracy adjustments (para 5-12) .

5-8. Alignment of Klystron Oscillator

- a. Remove the rf oscillator section from the signal generator.
- b. Disconnect connector A4P3 from jack A4
- c. Connect the multimeter as an ohmmeter across the pairs of connector A4P3 pins listed in the following chart and make the adjustment indicated to obtain the required resistance.

<i>Connector A4P3 pins</i>	<i>Adjustment potentiometer</i>	<i>Ohmmeter indication (ohms)</i>
B and C	800 MC (A4R5)	12,000
C and D	900 MC (A4R10)	12,000
F and H	1250 MC (A4R13)	5,000
H and J	1400 MC (A4R14)	12,000
J and L	1500 MC (A4R15)	12,000
L and M	1600 MC (A4R16)	12,000

- d. Set 600 MC, 1000 MC, 1100 MC and 1850 MC potentiometers (fig. 3-5) to midpoints of their mechanical travel.

- e. Connect connector A4P3 to jack A4JI.

- f. Install the rf oscillator section in the signal generator chassis.

- g. Connect the signal generator and the test equipment as shown in figure 5-2.

- h. Connect the multimeter as a voltmeter between test points A4TP5 (+) and A4TP8 (-).

- i. Set MODULATION selector switch to CW position.

- j. Set POWER OFF toggle switch to the up position and allow the signal generator to warm up for 30 minutes.

- k. Set the center frequency selector handwheel as indicated in the following chart and make the adjustments to obtain the multimeter voltage indications shown.

NOTE

Repeat the adjustments until no further adjustments are required.

<i>Center frequency selector handwheel setting (MHz)</i>	<i>Adjustment potentiometer</i>	<i>Multimeter voltage indication (volts)</i>
600	600 MC (A4R3)	50
1000	1000 MC (A4R6)	200
1850	1850 MC (A4R19)	250
1100	1100 MC (A4R8)	80

l. Set the center frequency selector handwheel as indicated in the following chart and make the adjustments shown to obtain maximum indications on the wattmeter; make each adjustment in incremental steps.

NOTE

Repeat each set of prior adjustments before proceeding to the next adjustment, to obtain the maximum power output throughout the entire frequency range.

Center frequency selector handwheel (MHz)	Adjustment potentiometer	Wattmeter indication
600	600 MC (A4R3)	maximum
1000	1000 MC (A4R6)	maximum
1850	1850 MC (A4R19)	maximum
1100	1100 MC (A4R8)	maximum

m. Perform the klystron beam current adjustment and repeat the procedure outlined in l above.

n. Operate the center frequency selector handwheel through the ranges listed in the chart below.

o. Set the ATTENUATOR control as required for wattmeter indications, but not more than - 7 dbm and make the tracking adjustments indicated for maximum wattmeter indication.

Center frequency selector handwheel range (MHz)	Adjustment potentiometer	Wattmeter indication
725 to 850	800 MC (A4R5)	maximum
850 to 975	900 MC (A4R10)	maximum
1200 to 1350	1250 MC (A4R13)	maximum
1350 to 1460	1400 MC (A4R14)	maximum
1460 to 1550	1500 MC (A4R15)	maximum
1550 to 1720	1600 MC (A4R16)	maximum

p. Repeat the procedure outlined in l through o above until no further adjustments are required.

q. Set POWER OFF toggle switch to OFF position and disconnect the test equipment.

5-9. RF Output Frequency Test

a. Connect the equipment as shown in figure 5-1.

b. Set Frequency Meter TS-186D/U controls as follows:

- (1) POWER switch: ON
- (2) IND switch: BEAT IND
- (3) XTAL CAL: ON
- (4) VOLUME control: Max ccw
- (5) HET Osc: ON

- c. Set controls of the AN/URM-149 as follows:
 - (1) POWER OFF toggle switch: on (up)
 - (2) MODULATION selector switch: cw
 - (3) ATTENUATOR MICROVOLTS/-DBM control: -10 dbm
 - (4) Center frequency selector handwheel: 600

d. Turn on the TS-186D/UP and allow a minimum 2 hour warmup period before proceeding.

e. Calibrate the TS-186D/UP by turning the IND switch to each of its positions.

f. Compare the meter indications with those listed in the following chart:

IND SWITCH position	Meter indication
BEAT IND	.8 - .9
DET	.2 - .4
XTAL	.02 - .05
HET OSC	.6 - .95

g. Make certain that the IND switch is in the HET OSC position.

h. Determine the dial setting corresponding to the 600 MHz reading and set the TUNING DIAL and assembly accordingly; refer to the calibration manual.

i. Put on the headset.

j. Adjust the volume control until the background noise is at a comfortable listening level.

k. Adjust the TUNING DIAL for zero beat in the vicinity of the setting determined in f above.

NOTE

Frequency meter zero beat must be observed between 597 and 603 MHz.

l. Repeat the procedure outlined in e and f above at each frequency indicated in the chart below, making certain not to move the TUNING DIAL.

600-1850 MC FREQUENCY MC counter	FREQUENCY METER REQUIRED ZERO BEAT LIMITS	
	MINIMUM (MHz)	MAXIMUM (MHz)
600	597	603
700	697.9	702.1
800	796.6	802.4
900	897.3	902.7
1000	997	1005
1100	1096.7	1103.3
1200	1196.4	1203.6

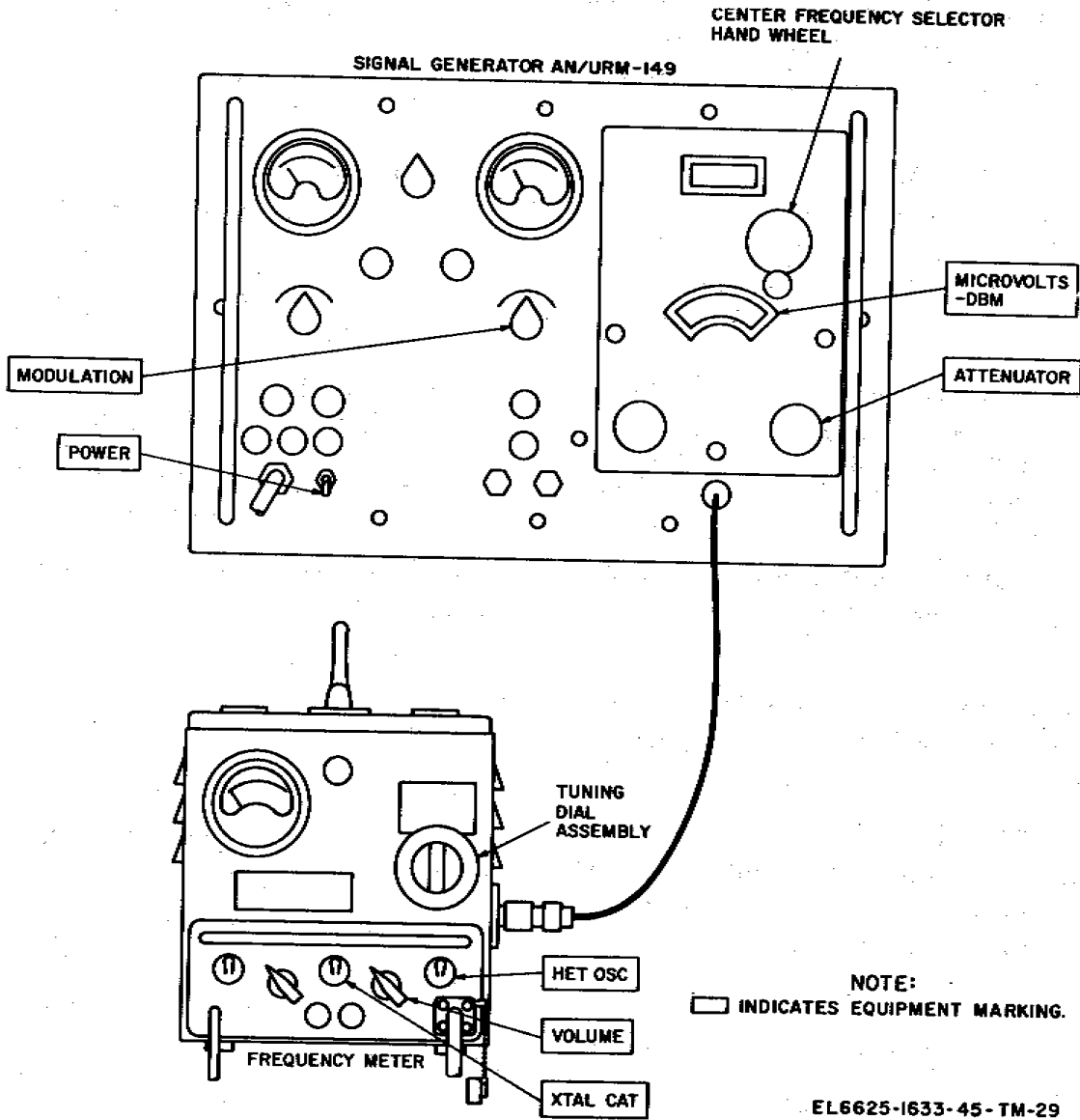

Figure 5-1. Rf output frequency, test setup diagram.

600-1850 MC FREQUENCY MC counter	FREQUENCY METER REQUIRED ZERO BEAT LIMITS	
	MINIMUM (MHz)	MAXIMUM (MHz)
1300	1296.1	1303.9
1400	1395.8	1404.2
1500	1495.5	1504.5
1600	1595.2	1604.8
1700	1694.9	1705.1
1800	1794.6	1805.4
1850	1844.45	1855.55

- (1) POWER RANGE 0.3 MW/ - 5DBM
- (2) ZERO SET: Fully clockwise
- (3) COEF: NEG
- (4) RES: 200
- (5) BIAS CURRENT: OFF
- (6) ON: ON

d. Set the controls of the AN/URM-149 as follows:

- (1) ATTENUATOR -7
MICROVOLTS/
DBM control:
- (2) Center frequency 600
selector handwheel:
- (3) MODULATION OFF
selector switch:
- (4) POWER OFF on (up)
toggle switch:

5-10. RF Output Power Test

- a. Connect the equipment as shown in figure 5-2 but do not connect waveguide probe MX2144/U to the signal generator.
- b. Allow the equipment to warmup for 30 minutes.
- c. Set Wattmeter AN/URM-98 controls as follows:

- e. Adjust the wattmeter by placing the BIAS CURRENT switch in the 0-6 position.
- f. Observe the meter; if the meter remains off scale at the high end or moves down to a position on scale, proceed to step g and h below. If the meter pointer reverses its position and rests off scale at the low end, proceed to step i, j and k below.
- g. Zero set the meter with the ZERO SET controls by rotating the COARSE control counterclockwise until the pointer on the meter is as close as possible to zero.
- h. Rotate the FINE control counterclockwise until the meter pointer rests on zero.
- i. Rotate BIAS CURRENT switch one step at a time to increase bias current.
- j. Continue until the meter pointer moves on or off scale at the high end.
- k. Zero set the meter as described in g and h above.

NOTE

After each step, and with the MODULATION selector switch in OFF position, re-set the wattmeter.

- l. Adjust the AN/URM-149 ZERO SET control for a ZERO SET indication on the power set meter (red reference line).
- m. Set MODULATION selector switch to CW position.
- n. Adjust POWER SET control for power set meter indication at the red reference line.
- o. Set ATTENUATOR for a -7 dbm indication.
- p. Set the center frequency selector handwheel to each of the positions indicated in the chart below; wattmeter indications must be within the limits specified.

NOTE

For each position of the center frequency selector handwheel, set the

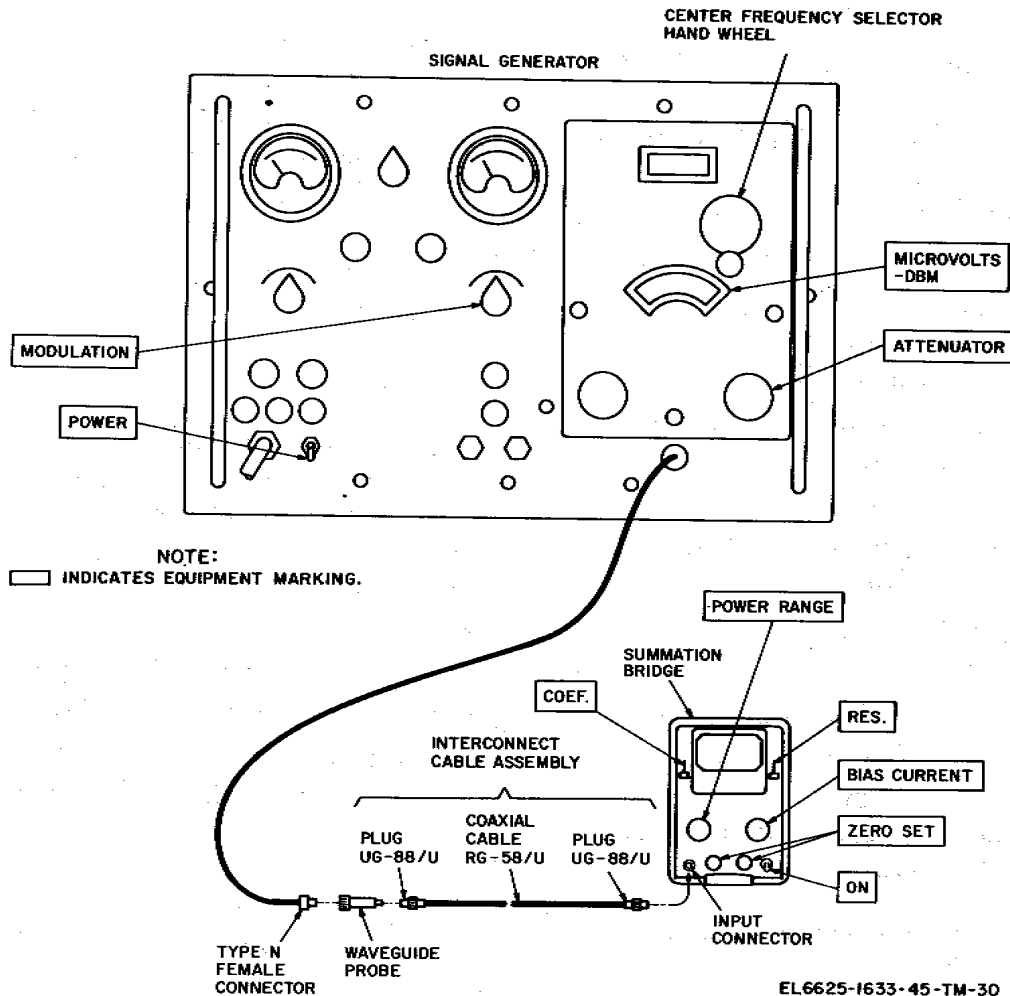

Figure 5-2. Rf output power, test setup diagram.

TM 11-6625-1633-45

MODULATION selector switch to OFF and repeat the procedures in *l* through *o* above. Then reset the wattmeter.

600-1850 MC FREQUENCY MC counter	WATTMETER INDICATOR	
	MINIMUM (DBM)	MAXIMUM (DBM)
600	-8	-6
700	-8	-6
800	-8	-6
900	-8	-6
1000	-8	-6
1100	-8	-6
1200	-8	-6
1300	-8	-6
1400	-8	-6
1500	-8	-6
1600	-8	-6
1700	-8	-6
1800	-8	-6
1850	-8	-6

5-11. Rf Output Resistance Test

- a. Set the controls of the TS-352B/U as follows:
 - (1) FUNCTION switch to OHMS.
 - (2) Range switch to RX1 position.
- b. Set the controls of the AN/URM-149 as follows:
 - (1) Center frequency selector hand wheel to 700.
 - (2) POWER OFF toggle switch to on (up).
- c. Short-circuit the multimeter test leads.
- d. Adjust the OHMS ZERO ADJ to position the multimeter pointer directly over the zero on the right side of the OHMS scale.
- e. Measure the resistance across the signal generator RF OUTPUT jack.

NOTE

The multimeter indication should be between 45 and 55 ohms.

- f. Set the AN/URM-149 center frequency selector hand-wheel to 1400.
- g. Measure the resistance across the signal generator RF OUTPUT jack.

NOTE

The multimeter indication should be between 45 and 55 ohms.

5-12. Internal Modulation Frequencies Accuracy Test

- a. Connect the equipment as shown in figure 5-3.

- b. Allow a 2 hour warmup period for the equipment.
- c. Set the controls of Frequency Meter TS 186D/UP as follows:

- | | |
|-----------------|----------|
| (1) POWER: | ON (up) |
| (2) IND switch: | BEAT IND |
| (3) XTAL CAL: | ON |
| (4) VOLUME: | Max ccw |
| (5) HET OSC: | ON |

- d. Set the controls of the signal AN/URM 149 generator as follows:

- | | |
|--|-----------------|
| (1) POWER OFF toggle switch: | on (up) |
| (2) MODULATION selector switch: | INT SINE |
| (3) DEVIATION METER RANGE selector switch: | 300 KC |
| (4) INTERNAL MODULATION FREQUENCY selector switch: | 1000 cps |
| (5) DEVIATION control knob: | Fully clockwise |

- e. Calibrate the TS-186D/UP Frequency Meter by turning the IND switch to each of its positions, and comparing the meter indications listed in the chart below:

IND SWITCH position	METER INDICATION
BEAT IND	.8 - .9
DET	.2 - .2
XTAL	.02 - .05
HET OSC	.6 - .95

- f. At the proper dial setting corresponding to 1000 Hz, set the TUNING DIAL assembly (refer to the calibration manual).

- g. Put on the headset and adjust the VOLUME control until the background noise is at a comfortable listening level.

- h. Adjust the TUNING DIAL in the vicinity of the setting determined in *f* above.

- i. Set the AN/URM-149 INTERNAL MODULATION FREQUENCY selector switch to the positions which follow:

- (1) 1000 CPS
- (2) 1600 CPS
- (3) 20 KC
- (4) 68 KC
- (5) 108 KC

- j. Tune the frequency meter for zero beat at each frequency.
- k. Observe that frequency meter zero beat is within the limits specified in the chart below:

MINIMUM	MAXIMUM
990 Hz	1010 Hz
15.84 Hz	1616 Hz
19.8 KHz	20.2 KHz
67.32 Khz	68.68 KHz
106.92 KHz	109.08 KHz

5-13. RF Noise Level Test

- a. Connect the equipment as shown in figure 5-4.
- b. Allow the equipment a 2 hour warmup period before starting procedure.
- c. Set controls of Modulation Meter ME-57/U as follows:
 - (1) POWER: ON (up)
 - (2) FREQUENCY RANGE: 500-1000

- d. Set the controls of the AN/URM-149 as follows:
 - (1) POWER OFF toggle switch: ON (up)
 - (2) INTERNAL MODULATION FREQUENCY selector switch: 20 kc
 - (3) DEVIATION METER RANGE selector switch: 300 kc
 - (4) MODULATION selector switch: INT SINE

- e. Set the Spectrum Analyzer 723/U POWER switch to DN.
- f. Normalize the AN/URM-149 by setting the FREQUENCY MC counter for an indication of 600 MHz.
- g. Adjust the ME-57/U TUNING control for a maximum deflection of LIMITING meter, with the CARRIER SHIFT meter indicating zero.

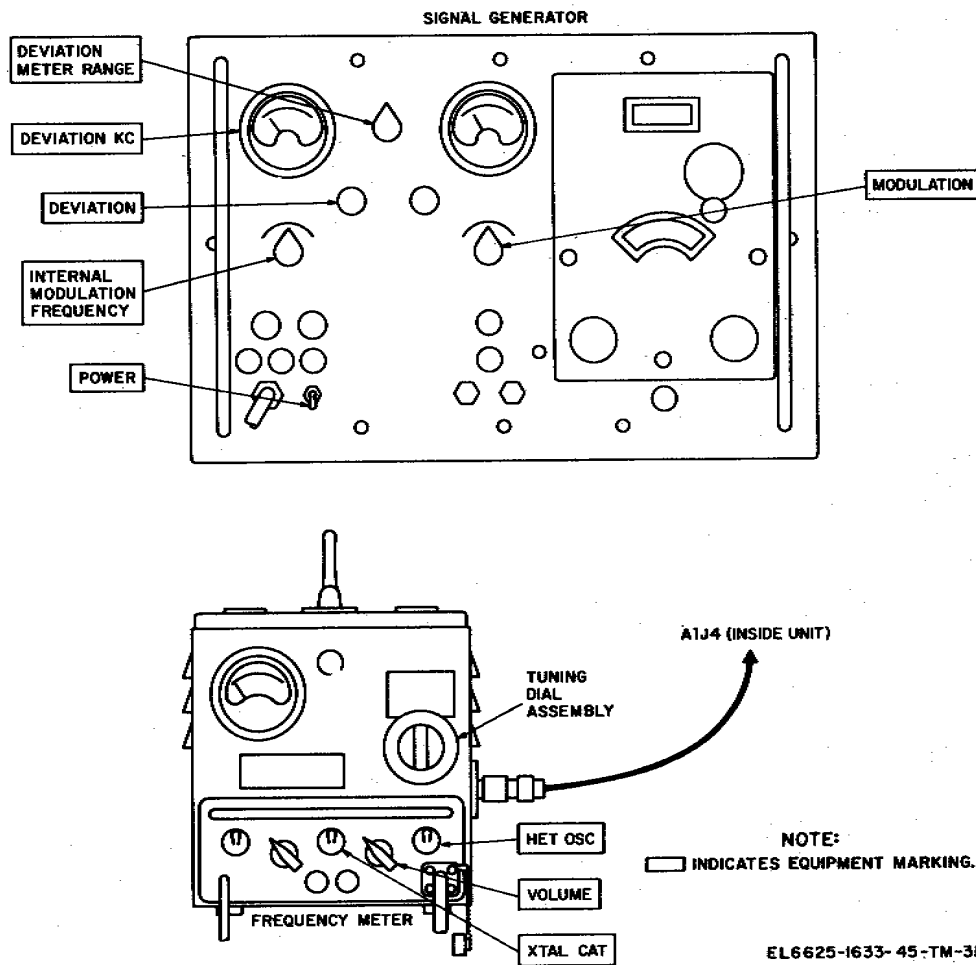

Figure 5-3. Internal modulation frequency accuracy, test setup diagram.

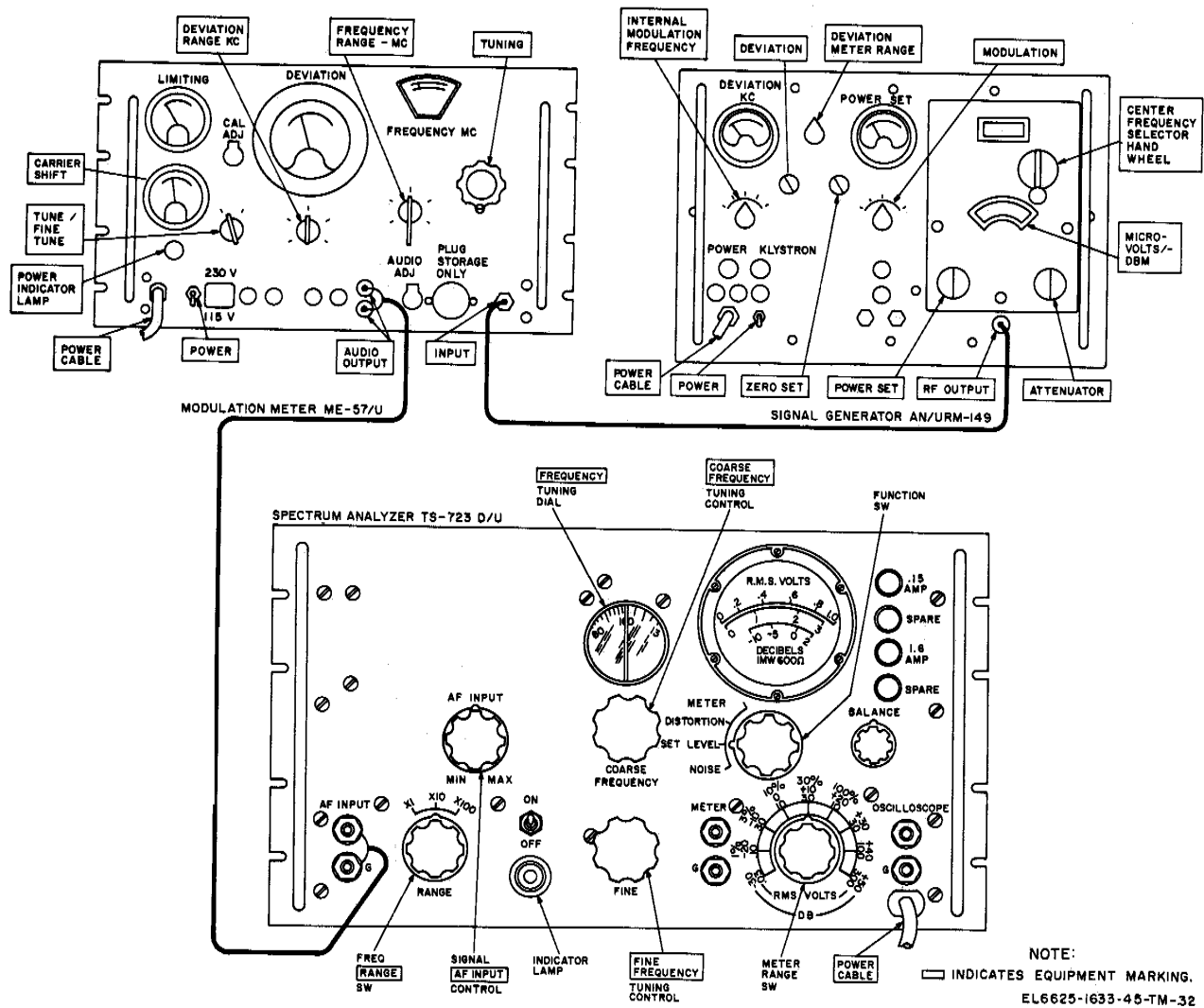

Figure 5-4. Rf noise level measurement, test setup diagram.

Figure 5-4. Rf noise level measurement, test setup diagram

h. Set the ATTENUATOR control for in-red deflection on LIMITING meter.

i. Adjust the AN/URM-149 DEVIATION control knob until the DEVIATION meter indicates 300.

j. Adjust the TS-723D/U COARSE FREQUENCY tuning dial to 20 KHz.

k. Adjust the FINE FREQUENCY tuning control to obtain peak meter reading on the TS-723D/U

l. Observe and note meter reading.

m. Tune the frequency of the TS-723D/U from 150 Hz through 18 KHz.

n. Note db indications on the meter and calculate difference between reading obtained in *k* above.

NOTE

Make certain that no reading is more than -40 db below the reading obtained in *k* above.

o. Repeat the procedure outlined in *i* through *m* above under test frequency settings of 1000 MHz and 1850 MHz.

*Figure 5-5. Tube socket voltage and resistance diagram.
(Located in back of manual.)*

*Figure 5-6. Resistor, inductor, and capacitor color code diagrams.
(Located in back of manual.)*

*Figure 5-7. Signal Generator AN/URM-149,
block diagram.
(Located in back of manual.)*

*Figure 5-8 ①. Signal Generator AN/URM-149, schematic diagram (part 1 of 2).
(Located in back of manual.)*

*Figure 5-8 ②. Signal Generator AN/URM-149,
schematic diagram (part 2 of 2).
(Located in back of manual.)*

APPENDIX

REFERENCES

Following is a list of applicable publications available to GS and depot maintenance personnel of Signal Generator AN/URM-149:

AR 380-5	Military Security
DA Pam 310-4	Index of Technical Manuals, Technical Bulletins, Supply Manuals (types 7, 8, and 9) Supply Bulletins, and Lubrication Orders
DA Pam 310-7	U. S. Equipment Index of Modification Work Orders
TM 11-2691-15	Frequency Meter TS-186D/UP
TM 11-6625-366-15	Organizational, DS, GS, and Depot Maintenance Manual: Multimeter TS-352B/U.
TM 11-6625-400-35	DS, GS, and Depot Maintenance Manual: Meter, Modulation ME-57/U.
TM 11-6625-433-15	Organizational, DS, GS, and Depot Maintenance Manual Including Repair Parts and Special Tool List: Wattmeter AN/URM-98 and AN/URM-98A
TM 11-6625-524-14	Operator, Organizational, and Field Maintenance Manual: Voltmeter, Electronic AN/URM-145
TM 11-6625-535-15	Operator, Organizational, DS, GS, and Depot Maintenance Manual: Oscilloscope AN/USM-140
TM 11-6625-537-15	Operator, Organizational, Field and Depot Maintenance Manual: Differential Voltmeter ME-202/U.
TM 11-6625-1633-12	Operator and Organizational Maintenance Manual: Signal Generator AN/URM-149.
TM 11-6625-1633-45P	Repair Parts and Special Tool List: Signal Generator AN/URM-149.
TM 38-750	The Army Maintenance Management System (TAMMS)
TM 740-90-1	Administrative Storage of Equipment.

INDEX

	Paragraph	Page
Alignment of klystron oscillator	5-8	5-2
Analysis of beam power supply	2-8	2-5
Analysis of deviation metering circuit	2-4	2-2
Analysis of internal modulator oscillator circuit	2-2	2-1
Analysis of klystron filament power supply	2-10	2-6
Analysis of klystron oscillator circuit	2-5	2-3
Analysis of measurements	3-10	3-16
Analysis of modulator amplifier circuit	2-3	2-2
Analysis of modulator and bridge power supply	2-9	2-5
Analysis of power distribution	2-11	2-6
Analysis of power monitor bridge circuit	2-6	2-4
Analysis of reflector power supply	2-7	2-4
Applicability of depot overhaul standards	5-3	5-1
Applicable references	5-4	5-1
Block diagram analysis:		
Deviation metering circuit	2-1c	2-1
Internal modulator oscillator circuit	2-1a	2-1
Klystron oscillator circuit	2-1d	2-1
Modulation amplifier circuit	2-1b	2-1
Power monitor bridge circuit	2-1e	2-1
Power supplies	2-1f	2-1
Checking filament and plate voltage circuits for shorts	3-4	3-4
DC resistance and voltage readings of transformers and coils	3-16	3-19
Depot maintenance:		
General	5-1	5-1
Maintenance procedures	5-2	5-1
Deviation accuracy adjustments	4-19	4-7
Deviation meter adjustment	4-18	4-7
General maintenance instructions	3-1	3-1
General parts replacement techniques	4-1	4-1
In-circuit transistor tests	3-11	3-17
In-circuit transistor resistance checks of module HR2	3-12	3-17
Internal modulation frequencies accuracy test	5-12	5-6
Isolating trouble to a diode	3-15	3-19
Isolating trouble within a transistor stage	3-9	3-16
Isolating trouble within a vacuum tube stage	3-8	3-16
Klystron beam current adjustment	4-14	4-6
Maintenance forms and records	1-2	1-1
Modulation oscillator output adjustment	4-17	4-7
Out-of-circuit tests of module HR2:		
Resistance checks at chassis socket of module HR2	3-13b	3-17
Resistance values of module HR2	3-13c	3-17
Voltage checks at chassis socket of module HR2	3-13a	3-17
Out-of-circuit transistor tests	3-14	3-18
Physical tests and inspections	5-5	5-1
Power monitor bridge adjustment	4-15	4-6
Power supply voltage adjustments	4-13	4-5
Removal and replacement of attenuator probes	4-6	4-3
Removal and replacement of microswitches A4S1 and A4S2	4-7	4-3
Removal and replacement of rf oscillator section	4-2	4-1

TM 11-6625-1633-45

	Paragraph	Page
Removal and replacement of terminal boards	4-3	4-2
Replacement of 'coaxial relay K4	4-11	4-5
Replacement of frequency tracking springs	4-10	4-5
Replacement of frequency travel stop screws	4-9	4-4
Replacement of klystron	5-7	5-2
Replacement of tape cam	4-8	4-4
Removal and replacement of thermistor A4RT2 and A4RT3	4-5	4-3
Removal and replacement of tracking potentiometers A4R20 and A4R23	4-4	4-2
Rf noise level test	5-13	5-7
Rf output frequency test	5-9	5-3
Rf output power test	5-10	5-4
Rf output resistance test	5-11	5-6
Scope	1-1	1-1
Stage gain measurements	3-6	3-15
Test equipment and additional equipment required for depot maintenance	5-6	5-2
Test equipment and special tools required for alignment	4-12	4-5
Tools, materials, and test equipment required	3-2	3-1
Troubleshooting chart	3-5	3-13
Troubleshooting techniques	3-3	3-1
Waveform analysis	3-7	3-15

By Order of the Secretary of the Army:

CREIGHTON W. ABRAMS
General, United States Army
Chief of Staff

Official:

VERNE L. BOWERS
Major General, United States Army
The Adjutant General

Distribution:

To be distributed in accordance with DA Form 12-51. (qty rgr block no, 119) Direct and General Support maintenance requirements for AN/GRC-50.

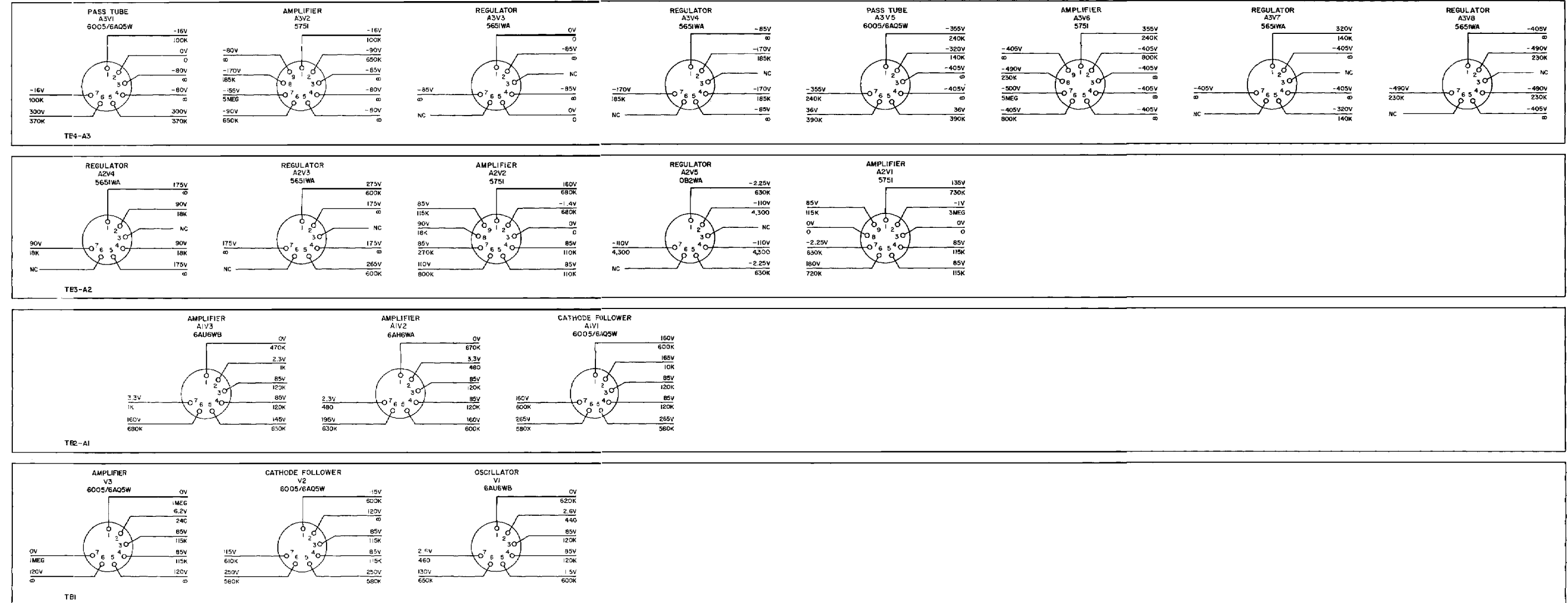
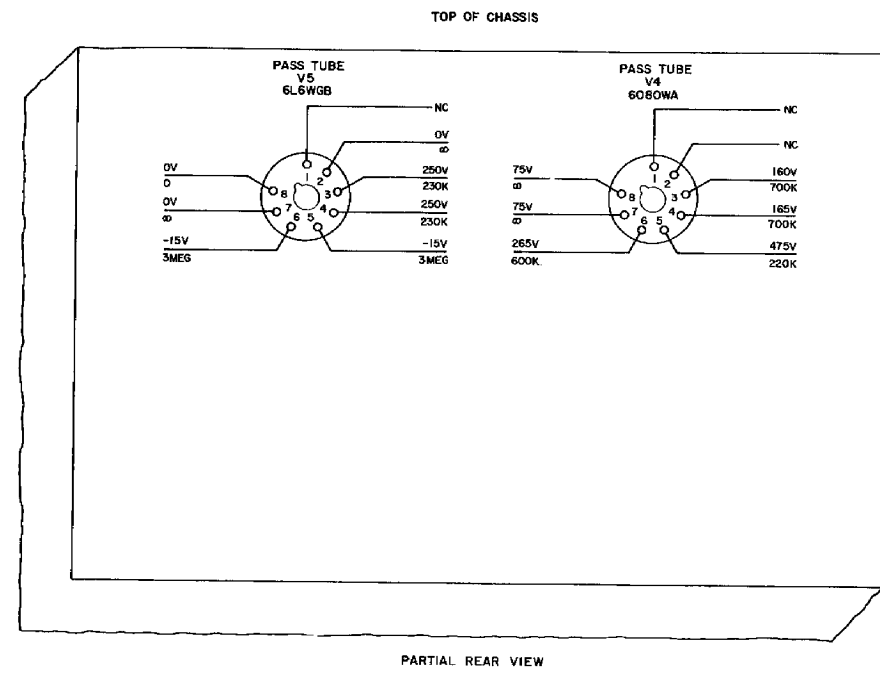

NOTES:
 1. VOLTAGE READINGS ABOVE LINE, RESISTANCE READINGS BELOW LINE.
 2. UNLESS OTHERWISE SHOWN, VOLTAGE AND RESISTANCES ARE MEASURED TO GROUND. DC VOLTAGE READINGS TAKEN WITH A 20,000 OHMS-PER-VOLT METER.
 3. NC INDICATES NO CONNECTIONS.

Figure 5-5. Tube socket voltage and resistance diagram

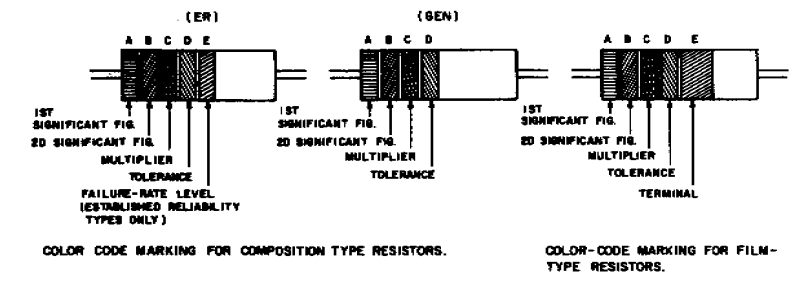

TABLE 1
COLOR CODE FOR COMPOSITION TYPE AND FILM TYPE RESISTORS.

BAND A		BAND B		BAND C		BAND D		BAND E	
COLOR	FIRST SIGNIFICANT FIGURE	COLOR	SECOND SIGNIFICANT FIGURE	COLOR	MULTIPLIER	COLOR	RESISTANCE TOLERANCE (PERCENT)	COLOR	FAILURE RATE LEVEL
BLACK	0	BLACK	0	BLACK	1	BROWN	M=1.0	BROWN	M=1.0
BROWN	1	BROWN	1	BROWN	10	RED	P=0.1	RED	P=0.1
RED	2	RED	2	RED	100	ORANGE	R=0.01	ORANGE	R=0.01
ORANGE	3	ORANGE	3	ORANGE	1,000	YELLOW	S=0.001	YELLOW	S=0.001
YELLOW	4	YELLOW	4	YELLOW	10,000	SILVER	±10 (COMP. TYPE ONLY)	WHITE	SOLDERABLE
GREEN	5	GREEN	5	GREEN	100,000	GOLD	±5		
BLUE	6	BLUE	6	BLUE	1,000,000	RED	±2 (NOT APPLICABLE TO ESTABLISHED RELIABILITY)		
PURPLE (VIOLET)	7	PURPLE (VIOLET)	7						
GRAY	8	GRAY	8	SILVER	0.01				
WHITE	9	WHITE	9	GOLD	0.1				

BAND A — THE FIRST SIGNIFICANT FIGURE OF THE RESISTANCE VALUE (BANDS A THROUGH D SHALL BE OF EQUAL WIDTH)

BAND B — THE SECOND SIGNIFICANT FIGURE OF THE RESISTANCE VALUE

BAND C — THE MULTIPLIER (THE MULTIPLIER IS THE FACTOR BY WHICH THE TWO SIGNIFICANT FIGURES ARE MULTIPLIED TO YIELD THE NOMINAL RESISTANCE VALUE.)

BAND D — THE RESISTANCE TOLERANCE.

BAND E — WHEN USED ON COMPOSITION RESISTORS, BAND E INDICATES ESTABLISHED RELIABILITY FAILURE-RATE LEVEL (PERCENT FAILURE PER 1,000 HOURS) ON FILM RESISTORS, THIS BAND SHALL BE APPROXIMATELY 1-1/2 TIMES THE WIDTH OF OTHER BANDS, AND INDICATES TYPE OF TERMINAL.

RESISTANCES IDENTIFIED BY NUMBERS AND LETTERS (THESE ARE NOT COLOR CODED)

SOME RESISTORS ARE IDENTIFIED BY THREE OR FOUR DIGIT ALPHA NUMERIC DESIGNATORS. THE LETTER R IS USED IN PLACE OF A DECIMAL POINT WHEN FRACTIONAL VALUES OF AN OHM ARE EXPRESSED. FOR EXAMPLE:
2R7 = 2.7 OHMS 10R0 = 10.0 OHMS

FOR WIRE-WOUND-TYPE RESISTORS COLOR CODING IS NOT USED, IDENTIFICATION MARKING IS SPECIFIED IN EACH OF THE APPLICABLE SPECIFICATIONS.

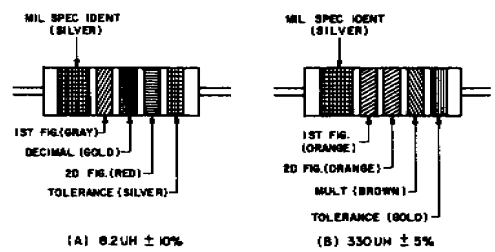
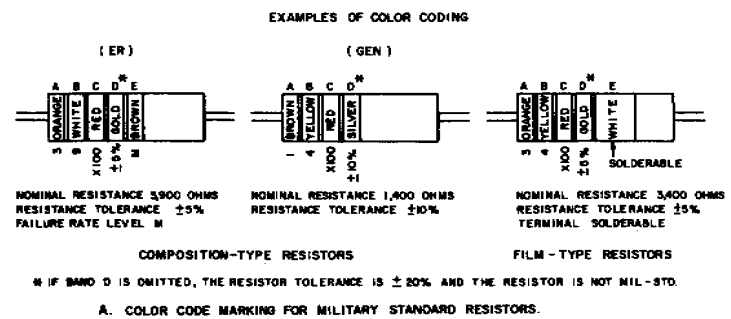

COLOR CODING FOR TUBULAR ENCAPSULATED R.F. CHOKES. AT A, AN EXAMPLE OF OF THE CODING FOR AN 0.2UH CHOKE IS GIVEN. AT B, THE COLOR BANDS FOR A 330 UH INDUCTOR ARE ILLUSTRATED.

TABLE 2
COLOR CODING FOR TUBULAR ENCAPSULATED R.F. CHOKES

COLOR	SIGNIFICANT FIGURE	MULTIPLIER	INDUCTANCE TOLERANCE (PERCENT)
BLACK	0	1	
BROWN	1	10	1
RED	2	100	2
ORANGE	3	1,000	3
YELLOW	4		
GREEN	5		
BLUE	6		
PURPLE (VIOLET)	7		
GRAY	8		
WHITE	9		20
NONE			10
SILVER			5
GOLD			DECIMAL POINT

MULTIPLIER IS THE FACTOR BY WHICH THE TWO COLOR FIGURES ARE MULTIPLIED TO OBTAIN THE INDUCTANCE VALUE OF THE CHOKE COIL.

B. COLOR CODE MARKING FOR MILITARY STANDARD INDUCTORS.

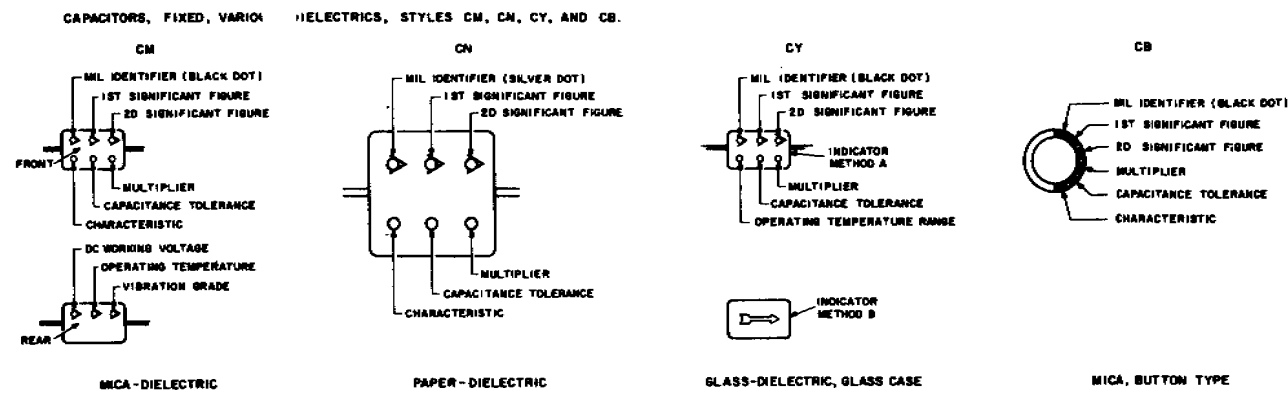

TABLE 3 — FOR USE WITH STYLES CM, CN, CY AND CB.

COLOR	MIL ID	1ST SIG FIG.	2D SIG FIG.	MULTIPLIER	CAPACITANCE TOLERANCE				CHARACTERISTIC			DC WORKING VOLTAGE	OPERATING TEMP RANGE	VIBRATION GRADE	
					CM	CN	CY	CB	CM	CN	CB				
BLACK	0	0	0	1											
BROWN	1	1	1	10											
RED	2	2	2	100	±5%										
ORANGE	3	3	3	1,000	±10%										
YELLOW	4	4	4	10,000											
GREEN	5	5	5		±5%										
BLUE	6	6	6												
PURPLE (VIOLET)	7	7	7												
GRAY	8	8	8												
WHITE	9	9	9												
GOLD				0.1											
SILVER	CM				±10%	±10%	±10%	±10%							

TABLE 4 — TEMPERATURE COMPENSATING, STYLE CC.

COLOR	TEMPERATURE COEFFICIENT	1ST SIG FIG.	2D SIG FIG.	MULTIPLIER	CAPACITANCE TOLERANCE		MIL ID
					CAPACITANCES OVER 10 UUF	CAPACITANCES 10 UUF OR LESS	
BLACK	0	0	0	1		±2.0 UUF	CC
BROWN	-30	1	1	10	±1%		
RED	-60	2	2	100	±2%	±0.25 UUF	
ORANGE	-150	3	3	1,000			
YELLOW	-220	4	4				
GREEN	-330	5	5		±5%	±0.5 UUF	
BLUE	-470	6	6				
PURPLE (VIOLET)	-750	7	7				
GRAY		8	8	0.01			
WHITE		9	9	0.1	±10%		
GOLD	+100					±1.0 UUF	
SILVER							

- THE MULTIPLIER IS THE NUMBER BY WHICH THE TWO SIGNIFICANT (SIG) FIGURES ARE MULTIPLIED TO OBTAIN THE CAPACITANCE IN UUF.
- LETTERS INDICATE THE CHARACTERISTICS DESIGNATED IN APPLICABLE SPECIFICATIONS: MIL-C-3, MIL-C-250, MIL-C-112728, AND MIL-C-10960C RESPECTIVELY.
- LETTERS INDICATE THE TEMPERATURE RANGE AND VOLTAGE-TEMPERATURE LIMITS DESIGNATED IN MIL-C-11018D.
- TEMPERATURE COEFFICIENT IN PARTS PER MILLION PER DEGREE CENTIGRADE.

C. COLOR CODE MARKING FOR MILITARY STANDARD CAPACITORS.

Figure 5-6. Resistor, inductor, and capacitor color code diagrams.

Figure 5-6. Resistor, inductor, and capacitor color code diagram.

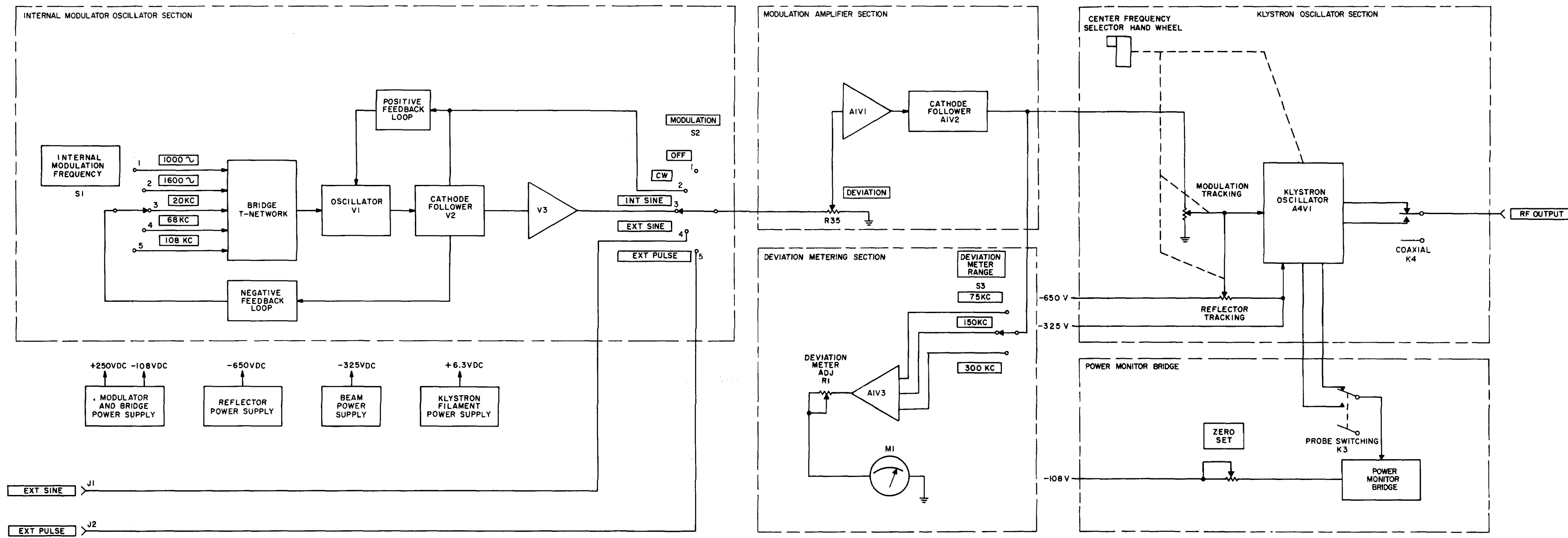

EL 6625-1633-45-TM-1

Figure 5-7. Signal generator AN/URM-149, block diagram.

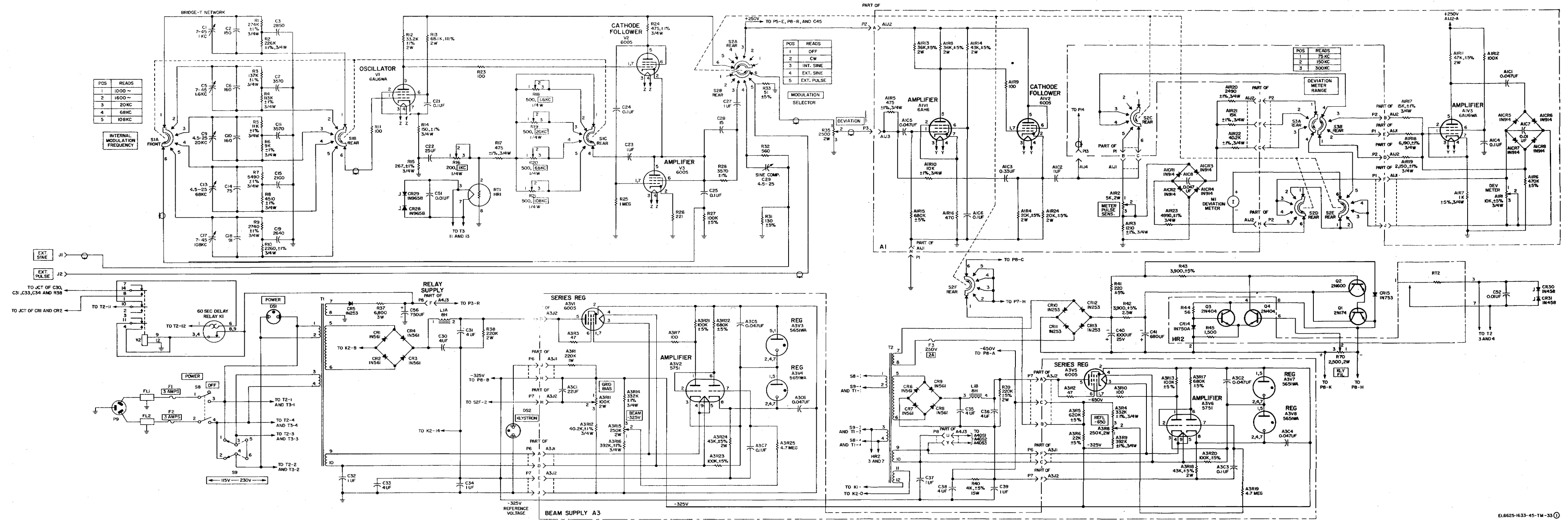

Figure 5-8 ①. Signal Generator AN/URM-149, schematic diagram (part 1 of 2).

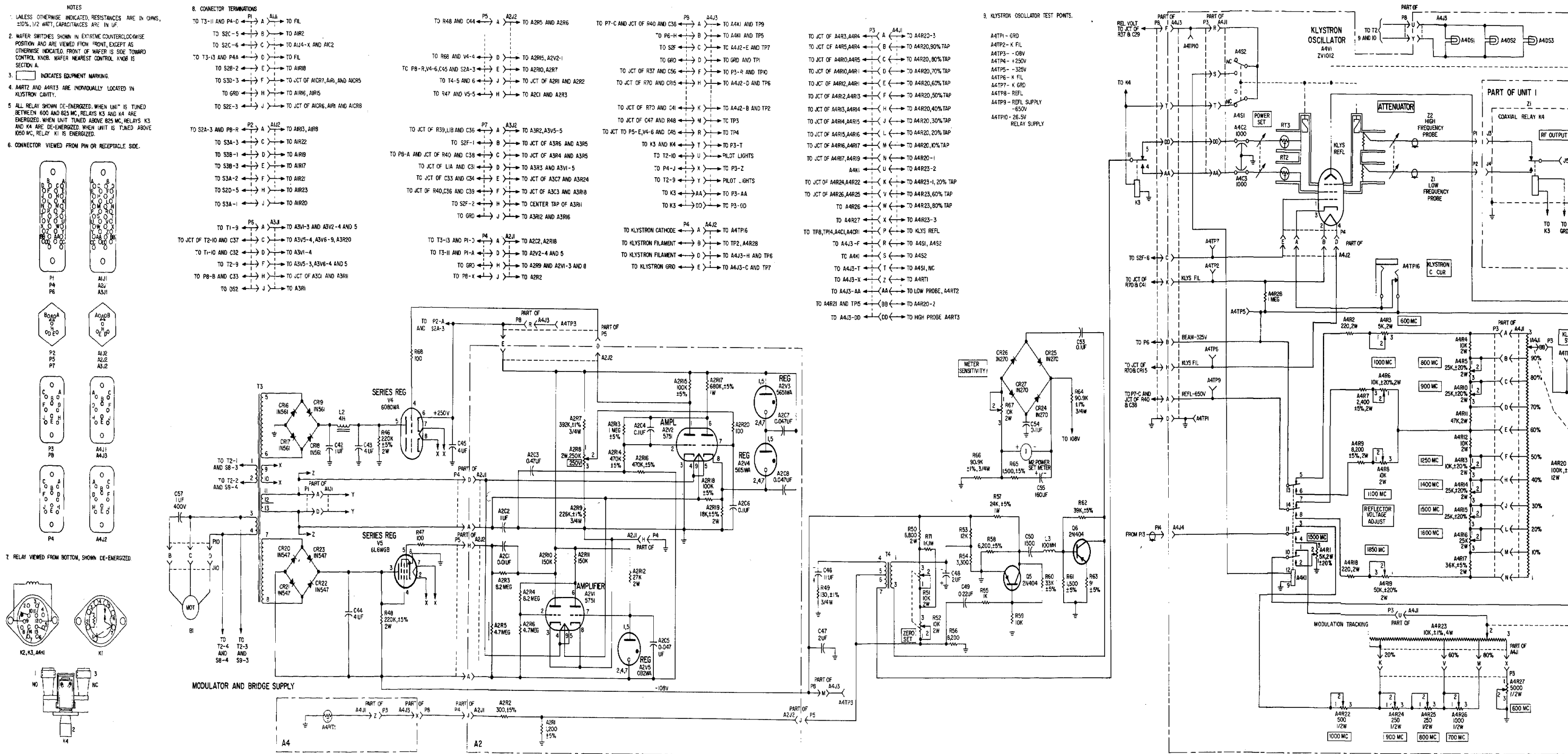

Figure 5-8 ②. Signal Generator AN/URM-149, schematic diagram (part 2 of 2).

RECOMMENDED CHANGES TO EQUIPMENT TECHNICAL PUBLICATIONS



THEN...JOT DOWN THE DOPE ABOUT IT ON THIS FORM. CAREFULLY TEAR IT OUT, FOLD IT AND DROP IT IN THE MAIL.

SOMETHING WRONG WITH PUBLICATION

FROM: (PRINT YOUR UNIT'S COMPLETE ADDRESS)

DATE SENT

PUBLICATION NUMBER

PUBLICATION DATE

PUBLICATION TITLE

BE EXACT PIN-POINT WHERE IT IS

PAGE NO.	PARA-GRAPH	FIGURE NO.	TABLE NO.

IN THIS SPACE, TELL WHAT IS WRONG AND WHAT SHOULD BE DONE ABOUT IT.

TEAR ALONG PERFORATED LINE

PRINTED NAME, GRADE OR TITLE AND TELEPHONE NUMBER

SIGN HERE

THE METRIC SYSTEM AND EQUIVALENTS

WEIGHT MEASURE

1 Centimeter = 10 Millimeters = 0.01 Meters = 0.3937 Inches
 1 Meter = 100 Centimeters = 1000 Millimeters = 39.37 Inches
 1 Kilometer = 1000 Meters = 0.621 Miles

WEIGHTS

1 Gram = 0.001 Kilograms = 1000 Milligrams = 0.035 Ounces
 1 Kilogram = 1000 Grams = 2.2 lb.
 1 Metric Ton = 1000 Kilograms = 1 Megagram = 1.1 Short Tons

LIQUID MEASURE

1 Milliliter = 0.001 Liters = 0.0338 Fluid Ounces
 1 Liter = 1000 Milliliters = 33.82 Fluid Ounces

SQUARE MEASURE

1 Sq. Centimeter = 100 Sq. Millimeters = 0.155 Sq. Inches
 1 Sq. Meter = 10,000 Sq. Centimeters = 10.76 Sq. Feet
 1 Sq. Kilometer = 1,000,000 Sq. Meters = 0.386 Sq. Miles

CUBIC MEASURE

1 Cu. Centimeter = 1000 Cu. Millimeters = 0.06 Cu. Inches
 1 Cu. Meter = 1,000,000 Cu. Centimeters = 35.31 Cu. Feet

TEMPERATURE

$5/9(^{\circ}\text{F} - 32) = ^{\circ}\text{C}$
 212° Fahrenheit is equivalent to 100° Celsius
 90° Fahrenheit is equivalent to 32.2° Celsius
 32° Fahrenheit is equivalent to 0° Celsius
 $9/5^{\circ}\text{C} + 32 = ^{\circ}\text{F}$

APPROXIMATE CONVERSION FACTORS

TO CHANGE	TO	MULTIPLY BY
Inches	Centimeters	2.540
Feet	Meters	0.305
Yards	Meters	0.914
Miles	Kilometers	1.609
Square Inches	Square Centimeters	6.451
Square Feet	Square Meters	0.093
Square Yards	Square Meters	0.836
Square Miles	Square Kilometers	2.590
Acres	Square Hectometers	0.405
Cubic Feet	Cubic Meters	0.028
Cubic Yards	Cubic Meters	0.765
Fluid Ounces	Milliliters	29.573
its	Liters	0.473
arts	Liters	0.946
allons	Liters	3.785
Ounces	Grams	28.349
Pounds	Kilograms	0.454
Short Tons	Metric Tons	0.907
Pound-Feet	Newton-Meters	1.356
Pounds per Square Inch	Kilopascals	6.895
Miles per Gallon	Kilometers per Liter	0.425
Miles per Hour	Kilometers per Hour	1.609

TO CHANGE	TO	MULTIPLY BY
Centimeters	Inches	0.394
Meters	Feet	3.280
Meters	Yards	1.094
Kilometers	Miles	0.621
Square Centimeters	Square Inches	0.155
Square Meters	Square Feet	10.764
Square Meters	Square Yards	1.196
Square Kilometers	Square Miles	0.386
Square Hectometers	Acres	2.471
Cubic Meters	Cubic Feet	35.315
Cubic Meters	Cubic Yards	1.308
Milliliters	Fluid Ounces	0.034
Liters	Pints	2.113
Liters	Quarts	1.057
ers	Gallons	0.264
ms	Ounces	0.035
ograms	Pounds	2.205
Metric Tons	Short Tons	1.102
Newton-Meters	Pounds-Feet	0.738
Kilopascals	Pounds per Square Inch	0.145
ometers per Liter	Miles per Gallon	2.354
ometers per Hour	Miles per Hour	0.621

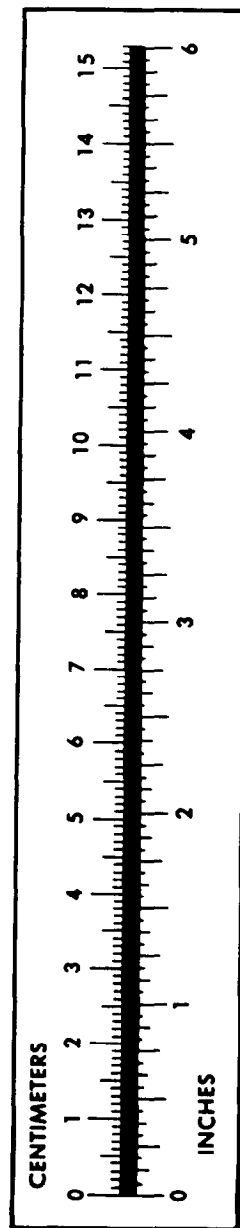

PIN: 016298-000